



# PROassist & CLEANassist

Functional furniture for the operating theatre, outpatient departments  
and for sterile supply and disposal

## Contents

|  |    |
|--|----|
| <b>PROassist &amp; CLEANassist</b>                     | 3  |
| Product Solutions for Selected Workflow Areas          | 4  |
| <b>PROassist</b>                                       | 6  |
| Operating Theatre and Ambulance Equipment              | 6  |
| Operating Theatre Equipment – Tables, Trolleys, Stands | 6  |
| Operating Theatre Seating                              | 12 |
| Mobile and Modular Assistants                          | 14 |
| Modular Equipment for Walls and Trolleys               | 15 |
| Instrument Trolleys                                    | 21 |
| Instrument Trolleys - Accessories                      | 23 |
| Multi-purpose Trolleys                                 | 24 |
| <b>CLEANassist</b>                                     | 26 |
| Packing  | 26 |
| Packing Station  | 27 |
| Packing Tables   | 28 |
| Tabletops  | 31 |
| Rack Attachments                                       | 32 |
| Rack Accessories                                       | 34 |
| Base Cabinets  | 35 |
| Accessories  | 36 |
| Transportation and Storage                             | 38 |
| Transport Trolleys                                     | 39 |
| General Transport Trolleys                             | 40 |
| Sterile Transport Trolleys                             | 41 |
| Storage Systems  | 43 |
| StU Storage Cabinets                                   | 44 |
| Slide-in / Pass-through Cabinets                       | 45 |
| StU Shelf  | 47 |
| Shelving Systems                                       | 48 |

# PROassist & CLEANassist

## Organised Solutions for Clinical Workflows

The **PROassist** and **CLEANassist** product lines comprise coordinated system solutions for selected functional areas within clinical workflows. Developed for use in hospitals, clinics, and other medical facilities, the ranges combine hygienic design, high-quality workmanship, and long-term reliability.

**PROassist** focuses on mobile equipment for highly dynamic clinical environments. The range includes operating theatre and ambulance equipment, modular and mobile assistants, instrument trolleys, and multipurpose trolleys designed for flexibility, stability, and reliable everyday use. With hygienic stainless-steel construction, excellent manoeuvrability, and durable workmanship, PROassist helps staff work safely, efficiently, and with maximum flexibility.

**CLEANassist** encompasses the structured processes surrounding packing, transport, and storage. The range includes ergonomic packing stations and tables, practical accessories and workstation components, transport trolleys, and flexible storage systems. Designed for hygiene, durability, and efficient handling, CLEANassist supports well-organised workflows in sterile goods logistics wherever safe packing, dependable transport, and appropriate storage are essential.

All products are manufactured from high-grade stainless-steel and designed to meet the requirements of modern medical environments for hygiene, durability, ease of cleaning, and operational reliability.

**Functional, hygienic, and durable equipment for daily use in medical environments**



# PROassist & CLEANassist

## Product Solutions for Selected Workflow Areas

The **PROassist** and **CLEANassist** product lines offer product solutions for defined workflow areas within clinical use, packing, transportation, and storage.

**MED-Systeme** covers key process areas where hygienic design, mobility, ergonomic handling, and robust construction are essential.

### Clinical Use

Within operating theatres, ambulances, and ward-related applications, **PROassist** supports daily procedures with mobile and stationary equipment designed for safe, flexible, and hygienic use. These include operating theatre equipment, operating theatre seating, modular assistants, instrument trolleys, and multi-purpose trolleys.

### Packing

For the packing area, **CLEANassist** provides ergonomic workstation solutions for the inspection, organisation, and packing of medical products and sterile goods. Packing stations, packing tables, tabletop variants, rack attachments, base cabinets, and accessories enable structured and application-oriented workstation design.



### Clinical Use

Equipment for operating theatres, ambulances, and wards



## Product Solutions for Selected Workflow Areas

### Storage

Cabinet and shelving systems for sterile goods storage



### Transportation

Trolley systems for internal transport



### Transportation

For internal transport processes, **CLEANassist** offers durable, easy-to-clean solutions for the safe movement of sterile goods and other medical equipment. The range includes general transport trolleys and sterile transport trolleys designed for reliable daily operation in medical environments.

### Storage

For storage applications, **CLEANassist** provides flexible systems for the hygienic and organised storage of sterile goods. The range includes storage cabinets, slide-in and pass-through cabinets, StU shelves, and shelving systems for adaptation to different room concepts and process requirements.

**PROassist and CLEANassist support defined workflow areas in clinical use, packing, transportation, and storage.**



### Packing

Workstation systems for inspection and packing



# PROassist

## Operating Theatre and Ambulance Equipment

### Designed for the Demands of the Operating Theatre

In the highly sensitive environment of the operating theatre, every product must fulfil two essential requirements: uncompromising hygiene and maximum functionality. Materials must meet the strictest hygiene standards, while every movement, process, and unit must support smooth, efficient workflows.

The **PROassist** range has been developed specifically to support operating theatre personnel in their daily work. It plays an important role in the sterile supply and disposal cycle, beginning with the use of sterile equipment in operating theatres, ambulances, and hospital wards.

MED-Systeme offers a comprehensive range of equipment for these demanding areas. Products such as suture material trays, glove dispensers, and writing desks are designed in accordance with StU standards. The range is complemented by versatile mobile assistants, including sterile supply tables, disposal tables, and hook trolleys.

These mobile units can be positioned quickly and easily wherever they are needed, providing a decisive advantage in dynamic and demanding medical environments.



## Operating Theatre Equipment – Tables, Trolleys, Stands

### Bowl Stands



1



2

#### The bowl stands securely hold solutions, liquids, cloths, etc.

Mobile 5-foot design made of stainless-steel and seamless welded. With push handle and removable stainless-steel bowl. Abrasion-resistant, non-discolouring, corrosion-resistant, synthetic antistatic double castors (5 steering castors, diameter 75 mm, 2 of which have brakes); Bowl: capacity 6 litres, outside diameter 320 mm.

|   | Model              | Weight | Dimensions (W x D x H) | Item no. |
|---|--------------------|--------|------------------------|----------|
| 1 | Bowl stand, single | 4 kg   | 635 x 670 x 865 mm     | 542 164  |
| 2 | Bowl stand, double | 7 kg   | 635 x 700 x 865 mm     | 542 165  |

# Instrument Tables



| <b>Mayo instrument table</b><br><b>All surgical instruments are well-organised and within reach on the mobile and height-adjustable mayo instrument table.</b>  |  |        |  |                   |
|---|--|--------|--|-------------------|
| Model   | Design   | Weight | Dimensions (W x D x H)   | Item no.          |
| <b>1 Mayo instrument table</b>  | Mobile 4-foot design made of stainless-steel and seamless welded. Sturdy, seamless deep-drawn tabletop made of stainless-steel, with rounded corners and edges. Manually height-adjustable from 830-1300 mm. Max. surface load: 30 kg<br>Abrasion-resistant, non-discolouring, corrosion-resistant synthetic double castors, 2 of which are electrically conductive (4 steering castors dia. 75 mm). | 22 kg  | Dimensions of tabletop:<br>640 x 440 mm<br><br>640 x 440 x 830/1300 mm | <b>542 182</b>    |
| <b>Hydraulic pump mayo instrument table</b><br><b>The practical mayo instrument table, easily height-adjustable using a foot pedal.</b><br>Heavy 3-foot design with tip safety and installed precision pump (closed hydraulic system, max. load 30 kg, maintenance-free, immediately ready for operation) for height adjustment from 950–1350 mm with foot pedal operation, frame construction and lifting column made of stainless-steel. Step bar provided with electrically-conductive rubber protection. Sturdy, seamless deep-drawn tabletop made of stainless-steel, with rounded corners and edges, can be rotated and locked.<br>Abrasion-resistant, non-discolouring, corrosion-resistant synthetic double castors, 1 is electrically conductive (3 steering castors dia. 75 mm) |  |        |  |                   |
| Model   | Design   | Weight | Dimensions (W x D x H)   | Item no.          |
| <b>2 Hydraulic pump mayo table</b>  | Tabletop: 640 x 440 mm   | 30 kg  | 730 x 540 x 950/1350 mm  | <b>543 270</b>    |
| <b>Hydraulic pump mayo table</b>  | Tabletop: 740 x 540 mm   | 31 kg  | 780 x 540 x 950/1350 mm  | <b>543 271</b>    |
| <b>Hydraulic pump mayo table - Lower version</b>  | Tabletop: 740 x 540 mm   | 28 kg  | 740 x 540 x 650/850 mm   | <b>543 271 01</b> |
| <b>Hydraulic pump mayo instrument table - Model Tübingen</b><br><b>All of the instruments can really be accommodated on this extremely large tabletop.</b><br>Made of stainless-steel, with installed precision pump (closed hydraulic system, max. load 30 kg, maintenance-free, immediately ready for operation) for height adjustment from 950–1350 mm. Especially large tabletop, can be rotated by 360° and can be locked.   |  |        |  |                   |
| Model   | Design   | Weight | Dimensions (W x D x H)   | Item no.          |
| <b>3 Hydraulic pump mayo table - Model Tübingen</b>   | Abrasion-resistant, corrosion-resistant double ball bearing castors (4 steering castors, dia. 125 mm, 2 of which have brakes), electrically conductive.  | 43 kg  | 1200 x 600 x 950/1350 mm   | <b>543 269</b>    |

For custom sizes, please contact your local authorized partner.

## Surgical Table



1

### Hand and arm surgical table

This surgical table is designed for surgery to the hand or arm. Manually height-adjustable, with radiolucent tabletop.

| Model                         | Design  | Weight | Dimensions (W x D x H)  | Item no. |
|-------------------------------|---|--------|-------------------------|----------|
| 1 Hand and arm surgical table | <p>Mobile 4-foot design made of stainless-steel and seamless welded. Tabletop with radiolucent upholstery, height 30 mm, can be removed or tilted to all sides with ball joint; can be tightly fixed in place with clamping lever.</p> <p>Manually height-adjustable from 760-1030 mm. Antistatic upholstery. Loading capacity: 15 kg.</p> <p>Abrasion-resistant, non-discolouring, corrosion-resistant synthetic double castors, 2 of which are electrically conductive (4 steering castors dia. 75 mm).</p> | 7 kg   | 450 x 450 x 760-1030 mm | 542 169  |

## Bucket Stands



2



3

### Bucket stand

For discarding consumables quickly in the operating theatre.

| Model                              | Design   | Weight | Dimensions (W x D x H)                                    | Item no. |
|------------------------------------|--|--------|---|----------|
| 2 Bucket stand without push handle | <p>Mobile, made of stainless-steel, jointless, with all-round electrically-conductive bumper ring, support for stainless-steel bucket. With stainless-steel bucket, approx. 15 litre volume.</p> | 6 kg   | 466 x 466 x 263 mm<br>upper edge of the bucket:<br>465 mm | 542 178  |
| 3 Bucket stand with push handle    | <p>With 4 synthetic double castors, 2 of which are electrically-conductive (dia. 50 mm).</p>   | 7 kg   | 466 x 466 x 263 mm<br>upper edge of the bucket:<br>465 mm | 542 180  |

## Laundry and Waste Trolleys



| <b>Laundry and waste trolley</b>  |        |                        |          |  |
|---|--------|------------------------|----------|--|
| <b>The transport trolley for worn surgical clothing or for waste of any type.</b>   |        |                        |          |  |
| Mobile, jointless tubular frame design made of stainless-steel, with hanging fixture which hold commercially-available laundry or waste sacks with 60/70 l volume, with moulded push handle. Special support frame prevents the laundry or waste sack from slipping through. With 4 synthetic double castors, 2 of which are electrically-conductive (dia. 75 mm), 2 castors with brake |        |                        |          |  |
| Model   | Weight | Dimensions (W x D x H) | Item no. |  |
| 1 Laundry and waste trolley, single for 1 laundry or waste sack   | 7 kg   | 575 x 350 x 777 mm     | 542 163  |  |
| 2 Laundry and waste trolley, double for 2 laundry or waste sacks  | 10 kg  | 1020 x 350 x 777 mm    | 542 166  |  |



| <b>Laundry and waste trolley with foot pedal</b>   |         |        |                        |          |
|--|---------|--------|------------------------|----------|
| <b>The transport trolley for worn surgical clothing or for waste of any type.</b>  |         |        |                        |          |
| Mobile, jointless tubular frame design made of stainless-steel, with hanging fixture which hold commercially-available laundry or waste sacks with 60/70 l volume, with moulded push handle and with foot pedal. Special support frame prevents the laundry or waste sack from slipping through. With 4 synthetic double castors, 2 of which are electrically-conductive (dia. 75 mm), 2 castors with brake. |         |        |                        |          |
| Model  | Castors | Weight | Dimensions (W x D x H) | Item no. |
| 3 Laundry and waste trolley, single for 1 laundry or waste sack with foot pedal, synthetic lid   |         | 7 kg   | 575 x 350 x 777 mm     | 542 172  |
| 4 Laundry and waste trolley, double for 2 laundry or waste sacks with foot pedal, synthetic lid  |         | 10 kg  | 1020 x 350 x 777 mm    | 542 173  |
| <b>Synthetic lid for waste trolley</b>   |         |        | 403 x 360 mm           | 543 521  |
| Synthetic, for retrofitting on MED transport trolley for laundry and waste sacks.  |         |        |                        |          |

## Infusion Stand



|   |  |               |                               |
|---|--|---------------|-------------------------------|
| <b>Infusion stand</b>   |  |               |                               |
| <b>Practical one-hand mode</b>  |  |               |                               |
| Made of stainless-steel, 5-foot design seamless welded. Height-adjustable from 1520–2200 mm using one-hand height adjustment, with aqua gland with synthetic sealing ring and control ring; including stainless-steel bottle holder with 4 safety infusion hooks. With drip vessel and holder; loading capacity per hook: 2 kg. Non-discolouring, corrosion-resistant synthetic antistatic double castors (5 steering castors, dia. 75 mm, 2 of which have brakes). |  |               |                               |
|   | <b>Model</b>                                       | <b>Weight</b> | <b>Dimensions (W x D x H)</b> |
| <b>1</b>  | <b>Infusion stand<br/>Practical one-hand model</b> | 10 kg         | 630 x 630 x<br>1520/2200 mm   |
|   |  |               | <b>Item no.</b>               |
|   |  |               | <b>542 171</b>                |

## Shoe Racks

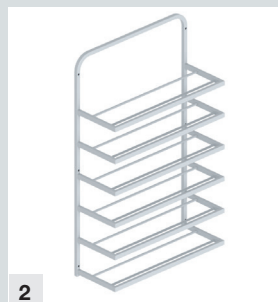

|  |  |  |               |                               |
|--|--|--|---------------|-------------------------------|
| <b>Operating theatre shoe racks</b>                        |  |  |               |                               |
| <b>Rack for the pre-operative and post-operative area.</b> |  |  |               |                               |
|  | <b>Model</b>                                     | <b>Design</b>  | <b>Weight</b> | <b>Dimensions (W x D x H)</b> |
| <b>1</b>   | <b>Operating theatre shoe rack, mobile</b>       | Mobile 4-foot design made of stainless-steel, seamless welded, with 6 stainless-steel tube frame levels as a support for 24 pairs of operating theatre shoes of all sizes. Abrasion-resistant, non-discolouring, corrosion-resistant synthetic antistatic double castors (4 steering castors, dia. 75 mm, 2 of which have brakes). | 26 kg         | 970 x 580 x 1600 mm           |
| <b>2</b>   | <b>Operating theatre shoe rack, wall-mounted</b> | Stainless-steel frame construction, seamless welded, with 7 stainless-steel tube frame levels as a support for 30 pairs of operating theatre shoes of all sizes.   | 24 kg         | 894 x 345 x 1450 mm           |
|  |  |  |               | <b>Item no.</b>               |
|  |  |  |               | <b>542 187</b>                |
|  |  |  |               | <b>542 188</b>                |

## Step Stools

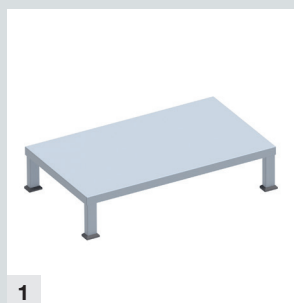

1



2



3



4

| Operating theatre step stool<br>With particularly durable feet. |                       |        |                        |          |
|---|-----------------------|--------|------------------------|----------|
| Model   | Capacity              | Weight | Dimensions (W x D x H) | Item no. |
| 1 Operating theatre step stool, single, 130 mm high             | Load capacity: 125 kg | 4 kg   | 600 x 350 x 130 mm     | 542 191  |
| 2 Operating theatre step stool, single, 220 mm high             | Load capacity: 125 kg | 5 kg   | 600 x 350 x 220 mm     | 542 192  |
| 3 Operating theatre step stool, single, 300 mm high             | Load capacity: 125 kg | 6 kg   | 600 x 350 x 300 mm     | 542 193  |
| 4 Operating theatre step stool, double, 220/440 mm high         | Load capacity: 100 kg | 9 kg   | 600 x 650 x 220/440 mm | 542 194  |



# Operating Theatre Seating

## Safety, comfort and reliability

Seating for use in the operating theatre must meet particularly demanding requirements. Safe electrical discharge of all components in the surgical area is essential for patient safety. In addition, operating theatre seating must be ergonomic, robust, hygienic, and easy to clean, and offer flexible height adjustment for optimal working comfort.

MED-Systeme operating theatre swivel stools and rolling swivel chairs are designed to meet these requirements reliably and consistently, combining safety, durability, and comfort in one professional solution.

### Product features:

- Special surgical stool suitable for all surgical areas, especially operating theatres
- Stable stainless-steel safety base with five steering castors
- Abrasion-resistant, non-marking, corrosion-resistant synthetic twin castors
- Load-dependent braking system with electrically conductive castors
- Foot brake integrated into the base frame
- Height adjustment from 510 to 740 mm via gas spring
- Convenient foot-operated adjustment with a large, chromed safety foot ring

## Swivel Chairs



1



2



3



4

### Operating theatre rolling swivel chair

Mobile 5-castor design made of stainless-steel. Continuous height adjustment from 510–740 mm with installed gas pressure spring using foot operation with large, chromed safety foot bar; black electrically conductive upholstery with extension security lock according to DIN standards. Seat dia. 360 mm for round seat, 420 mm for saddle seat, upholstery thickness 100 mm for round seat, 80 mm for saddle seat, footprint dia. 480 mm, 140 kg loading capacity. Abrasion-resistant, non-discolouring, corrosion-resistant synthetic castors (5 steering castors, dia. 50 mm with double ball bearing, 3 of which are electrically conductive, foot brake integrated in the transport frame).

|   | Model  | Weight                | Backrest                          | Dimensions (W x D x H)      | Item no. |
|---|--|-----------------------|-----------------------------------|-----------------------------|----------|
| 1 | Rolling swivel chair with round seat               | 25 kg net/30 kg gross | no backrest                       | 480 x 510-740 mm            | 344 351  |
| 2 | Rolling swivel chair with round seat and backrest  | 30 kg net/35 kg gross | with backrest adjustable by 45 mm | 480 x 510-740 mm + backrest | 344 352  |
| 3 | Rolling swivel chair with saddle seat              | 25 kg net/30 kg gross | no backrest                       | 480 x 510-740 mm            | 344 353  |
| 4 | Rolling swivel chair with saddle seat and backrest | 30 kg net/35 kg gross | with backrest adjustable by 45 mm | 480 x 510-740 mm + backrest | 344 354  |

# Swivel Stools



| <b>Swivel stools</b>  |        |   |                        |                |
|---|--------|---|------------------------|----------------|
| <b>Electrically conductive swivel stools for all functional rooms and for the OT</b>  |        |   |                        |                |
| Stainless-steel design with precision-spindle height adjustment, glass-bead blasted. Upholstered seats (dia. 340 mm) with electrically-conductive black cover. 140 kg load capacity.<br>Stationary models with electrically conductive-rubber feet. Mobile models with 5 steering castors, dia. 50 mm (abrasion-resistant, non-discolouring, corrosion-resistant synthetic double castors, 3 of which are electrically conductive). |        |   |                        |                |
| Model   | Weight | Castors   | Dimensions (W x D x H) | Item no.       |
| <b>1 Swivel stool with seat and spindle made of stainless-steel, glass-bead blasted</b><br>Stationary model with electrically conductive-rubber feet.   | 9 kg   | no castors  | 460 x 440-660 mm       | <b>344 355</b> |
| <b>2 Mobile swivel stool with seat and spindle made of stainless-steel, glass-bead blasted</b>  | 9 kg   | 5 steering castors, 50 mm dia., 3 electrically conductive | 460 x 480-700 mm       | <b>344 356</b> |



| Model   | Weight | Castors   | Dimensions (W x D x H) | Item no.       |
|---|--------|---|------------------------|----------------|
| <b>3 Swivel stool with flat upholstered seat (35 mm high)</b><br>Stationary model with electrically conductive-rubber feet. | 9 kg   | no castors  | 460 x 470-690 mm       | <b>344 357</b> |
| <b>4 Swivel stool with flat upholstered seat (35 mm high)</b>   | 9 kg   | 5 steering castors, 50 mm dia., 3 electrically conductive | 460 x 510-730 mm       | <b>344 358</b> |
| <b>5 Swivel stool with high upholstered seat (65 mm high)</b><br>Stationary model with electrically conductive-rubber feet. | 9 kg   | no castors  | 460 x 500-720 mm       | <b>344 359</b> |
| <b>6 Swivel stool with high upholstered seat (65 mm high)</b>   | 9 kg   | 5 steering castors, 50 mm dia., 3 electrically conductive | 460 x 540-760 mm       | <b>344 360</b> |

# Mobile and Modular Assistants

## Modular Solutions for Efficient Clinical Workflows

Our mobile assistants for operating theatres and outpatient departments are designed as complete modular solutions. Each trolley can be configured individually to meet specific requirements and workflows. This creates an efficient, well-organised system in which every item is exactly where it belongs.

All MED-Systeme products for the medical field are manufactured exclusively from stainless-steel. This material offers outstanding hygienic properties and can also be sterilised, making it ideally suited for demanding clinical environments. In addition, stainless-steel retains its high-quality appearance even after years of regular cleaning and disinfection.

### Key advantages:

#### Robust and hygienic

Manufactured from high-quality stainless-steel, our products are designed to withstand daily peak loads in demanding clinical environments. Smooth surfaces and seamless construction ensure optimum hygiene and reliable protection against viruses and bacteria.

#### Manoeuvrable

High-quality twin castors made of synthetic material ensure smooth handling and excellent manoeuvrability, allowing the units to be positioned quickly and precisely wherever they are needed.

#### Safe

The chassis is designed to provide maximum stability and tip resistance, even when a sterile supply table is loaded on one side only.



# Mobile Assistants

## Modular Equipment for Walls and Trolleys

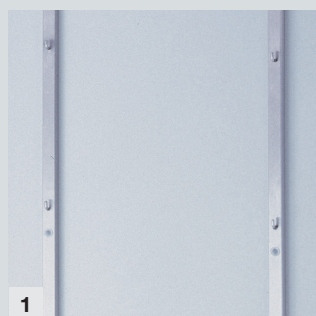

|   | Model   | Design   | Dimensions (W x D x H) | Item no.          |
|---|---|--|------------------------|-------------------|
| 1 | <b>Wall-mounted hook rail with 2 hooks</b>      | Made of stainless-steel 30 x 20 mm rectangular tubing, with 2 synthetic covers   | Length: 700 mm         | <b>542 210</b>    |
|   | <b>With 3 hooks</b>                             | Welded hooks, distance between hooks 350 mm, Hook capacity 60 kg per hook<br>Holds StU baskets or similar items  | 1050 mm                | <b>542 211</b>    |
|   | <b>With 4 hooks</b>                             |  | 1400 mm                | <b>542 212</b>    |
|   | <b>With 5 hooks</b>                             |  | 1750 mm                | <b>542 213</b>    |
|   | <b>With 7 hooks</b>                             | As above, but with 240 mm distance between<br>Holds 7 sterile equipment baskets, 1/2 StU   | 1600 mm                | <b>542 214</b>    |
| 2 | <b>Hook trolley One side (3 pairs of hooks)</b> | Mobile jointless square tube frame construction, 25 x 25 mm, made of stainless-steel, with hooks which have a maximum capacity of three 1 STE baskets or comparable articles. Hook loading capacity 60 kg per hook; abrasion-resistant, non-discolouring, corrosion-resistant synthetic antistatic double castors (4 steering castors, Ø 75 mm, 2 of which have brakes, with wall guards). | 600 x 460 x 1438 mm    | <b>542 208</b>    |
|   | <b>One side (4 pairs of hooks)</b>              |  | 600 x 460 x 1438 mm    | <b>542 208-01</b> |
| 3 | <b>Both sides (6 pairs of hooks)</b>            |  | 600 x 670 x 1438 mm    | <b>542 209</b>    |
|   | <b>Both sides (8 pairs of hooks)</b>            |  | 600 x 670 x 1600 mm    | <b>542 209-01</b> |



|   | Model                                  | Design  | Dimensions (W x D x H) | Item no.       |
|---|--|---|------------------------|----------------|
| 4 | <b>Multi-purpose storage</b>           | Seamless construction, holds folded paper   | 610 x 326 x 260 mm     | <b>542 222</b> |
| 5 | <b>Shoe rack</b>                       | Seamless construction, 12 suspension stirrups for max. 6 pairs of shoes, closed wire loops, wire thickness: 6 mm    | 600 x 263 x 180 mm     | <b>542 223</b> |
| 6 | <b>Tubing and abdominal cloth rack</b> | Stainless-steel, seamless construction, 11 welded hooks for anaesthesia tubing and/or abdominal cloths, offset      | 585 x 94 x 180 mm      | <b>542 224</b> |
| 7 | <b>Multipurpose equipment rack</b>     | E.g. for anaesthesia equipment, operating theatre accessories; seamless construction, solid sliding rail 25 x 10 mm | 600 x 48 x 180 mm      | <b>542 225</b> |

# Mobile Assistants

## Modular Equipment for Walls and Trolleys



1



2



3

|   | Model  | Design  | Dimensions (W x D x H)   | Item no.           |
|---|--|---|--|--------------------|
| 1 | <b>Stainless-steel housing for Plexiglas chutes</b>      | With 3 acrylic chutes in a stainless-steel housing, stackable | 601 x 172 x 245 mm   | <b>542 226</b>     |
|   |  | With 5 acrylic chutes in a stainless-steel housing, stackable | 601 x 172 x 171 mm   | <b>542 227</b>     |
| 2 | <b>Stainless-steel specialty container (without lid)</b> | Seamless, deep-drawn for MED wire mesh basket                 | 530 x 325 x 100 mm   | <b>1 550 590</b>   |
|   |  | <b>Holder for container above</b>                             | Seamless construction, holds specialty containers, with storage loop for lid | 550 x 325 x 320 mm |
| 3 | <b>Suture material storage</b>                           | With 4 shelves, holds max. 20 standard small-pack units       | 600 x 173 x 290 mm   | <b>542 230</b>     |



5



6



6

|   | Model                             | Design  | Dimensions (W x D x H)     | Item no.           |
|---|-----------------------------------|---|----------------------------|--------------------|
| 5 | <b>Glove dispenser</b>            | For max. 3 sizes of gloves, 50 pairs each       | 580 x 320 x 260 mm         | <b>542 231</b>     |
| 6 | <b>Shelf for urinal bottles</b>   | Seamless construction<br>Holds 5 urinal bottles | 580 x 276 x 230 mm         | <b>542 233</b>     |
|   |                                   | <b>Storage for 5 bedpans with lid</b>           | Holds 5 bedpans and 5 lids | 675 x 420 x 230 mm |
| 7 | <b>Storage shelf with console</b> | Seamless construction                           | 695 x 350 x 205 mm         | <b>542 235</b>     |
|   |                                   | With welded console                             | 695 x 450 x 240 mm         | <b>542 236</b>     |
|   |                                   | Load limit, even distribution: 50 kg            | 695 x 600 x 275 mm         | <b>542 237</b>     |

# Mobile Assistants

## Modular Equipment for Walls and Trolleys

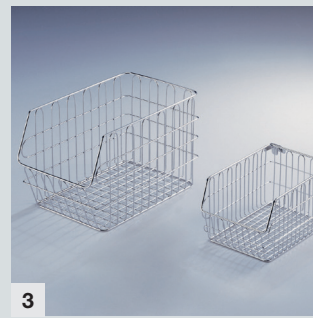
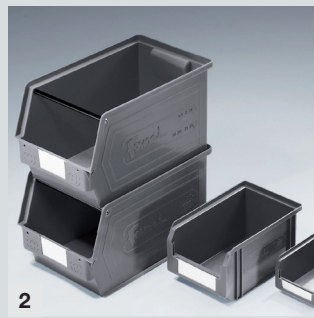

| <b>Universal holder</b><br>Made of stainless-steel, clean, jointless finish, for synthetic and wire containers.                   |  |        |  |  |                        |                   |
|---|--|--------|--|--|------------------------|-------------------|
| Model   | Design   |        | Material   | Dimensions (W x D x H)                     | Item no.               |                   |
| <b>1</b>  | <b>Universal synthetic and wire container holder - only the rail (without the synthetic container)</b> |        | Stainless-steel  | 550 x 37 x 170 mm                          | <b>542 220</b>         |                   |
| <b>Synthetic containers</b><br>Made of polypropylene. Stackable, can be suspended in holders for containers. Holds various goods. |  |        |  |  |                        |                   |
| <b>2</b>  | <b>Synthetic containers for use with universal holder, stackable</b>                                   | Size 3 | Blue   | Polypropylene                              | 350/300 x 200 x 200 mm | <b>5-522-0086</b> |
|   |  |        | Green  |  |                        | <b>5-522-0085</b> |
|   |  | Size 4 | Blue   |  | 230/200 x 140 x 130 mm | <b>5-522-0084</b> |
|   |  |        | Green  |  |                        | <b>5-522-0083</b> |
|   |  | Size 5 | Blue   |  | 160/140 x 95 x 75 mm   | <b>5-522-0082</b> |
|   |  |        | Green  |  |                        | <b>5-522-0081</b> |
| <b>3</b>  | <b>Wire mesh containers</b>  | Size 3 | Closed wire loops welded underneath the centre of the top frame, bottom frame designed as stacking frame | Stainless-steel, electrolytically polished | 215 x 350 x 200 mm     | <b>542 244</b>    |
|   |  | Size 4 |  |  | 153 x 231 x 125 mm     | <b>542 245</b>    |

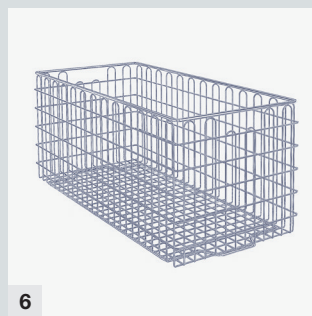

| Model    | Type                             | Design  | Weight  | Dimensions (W x D x H) | Item no.       |
|----------|----------------------------------|---|---------|------------------------|----------------|
| <b>4</b> | <b>Sterile equipment baskets</b> |   |         |                        |                |
| <b>5</b> | 1/2 STU                          | Stainless-steel, electrolytically polished, smooth finish, closed wire loops (2.5 mm), central weld underneath top frame (6 mm), lower frame (5 mm) designed for stacking (3 mm). | 1,82 kg | 575 x 280 x 135 mm     | <b>542 215</b> |
| <b>6</b> | 1 STU                            |   | 2,4 kg  | 575 x 280 x 265 mm     | <b>542 216</b> |
| <b>7</b> | 2 STU                            |   | 3,57 kg | 575 x 560 x 265 mm     | <b>542 218</b> |
| <b>8</b> | 1 STU                            | Mesh width: Wall 22 x 40 mm, Floor 22 x 22 mm; can be used with wall-mounted hook rail and hook trolley; capacity: 20 kg.   | 2,35 kg | 575 x 280 x 265 mm     | <b>542 217</b> |

# Mobile Assistants

## Modular Equipment for Walls and Trolleys



1

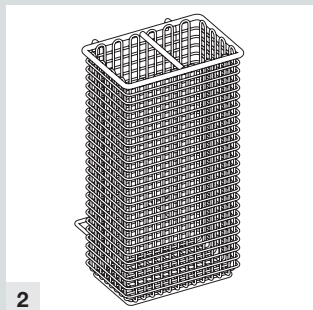

2

|   | Model  | Type  | Design  | Material  | Dimensions (W x D x H) | Item no.         |
|---|--|-------|---|---|------------------------|------------------|
| 1 | Sterile equipment basket with handle opening and hand grip opening on the long side, for use with equipment rail | 1 STU | Mesh width:<br>Floor: 22 x 22 mm<br>Walls: 22 x 40 mm<br><br>Capacity: 20 kg<br><br>Floor frame designed as a stacking frame;<br>TÜV tested | Stainless-steel, electrolytically polished, seamless construction | 575 x 280 x 265 mm     | <b>1 542 510</b> |
| 2 | Catheter basket, for use with the equipment rail   |       | With 2 hooks  | Stainless-steel, electrolytically polished                        | 150 x 100 x 200 mm     | <b>542 489</b>   |
|   |  |       |   |   | 150 x 100 x 280 mm     | <b>542 490</b>   |
|   |  |       |   |   | 150 x 100 x 480 mm     | <b>542 491</b>   |

# Mobile Assistants

## Modular Equipment for Walls and Trolleys



1



2



3

|   | Model  | Design  |  | Material                                   | Dimensions<br>(W x D x H) | Item no.       |
|---|--|---|--|--|---------------------------|----------------|
| 1 | <b>Wire mesh basket with folding handles</b> | Size 1, wire mesh basket, deep-drawn                                      | Closed base frame with cross spars for increased strength, 2 inner folding handles mounted on the short sides, mesh width: 4 x 4 mm. | Stainless-steel, electrolytically polished | 240 x 250 x 50 mm         | <b>542 247</b> |
| 2 | <b>Polypropylene container</b>               | Holds used instruments or a dirt sieve, can be sterilized at up to 134 °C | With solid lid   | Polypropylene                              | 300 x 225 x 125 mm        | <b>542 250</b> |
| 3 |  |   | With slotted lid   |  | 300 x 225 x 125 mm        | <b>542 251</b> |

## Mobile Assistants



1



2



3

### Mobile StU supply tables

Seamless 25 x 25 mm stainless-steel square tubular construction, tabletop to support StU standard containers, microlized, 30 mm bevel on all sides, inner edge bevelled downwards 45°

2 pairs of suspended slide-in rails underneath the tabletop:

1 pair of hook-in angled support brackets to hold a container lid

1 pair of hook-in angled support brackets to hold a 1 StU container

4 double antistatic synthetic castors (4 castors Ø 75 mm, 2 of them lockable)

| Model                      | Design   | Dimensions (W x D x H) | Item no. |
|----------------------------|--|------------------------|----------|
| 1 1 x 1 StU                | Tabletop to hold 1 container, 1 StU  | 400 x 660 x 900 mm     | 542 415  |
| 2 2 x 1 StU                | Tabletop to hold 2 containers, 1 StU;<br>solid foot stand made of bend square-type tube over the entire width of the tabletop for maximum tip resistance | 655 x 655 x 900 mm     | 542 416  |
| 3 StU disposal table 1 StU | Tabletop set into the tubular steel frame, easy to remove  | 400 x 660 x 900 mm     | 542 417  |



4



5



6

### Container transport trolley

Mobile, seamless 25 x 25 mm stainless-steel square tubular frame construction

| Model  | Design   | Castors   | Dimensions (W x D x H) | Item no. |
|--|--|---|------------------------|----------|
| 4 <b>Container transport trolley</b><br>Loading height: 300 mm | For easy transportation of one 2 StU basket or two 1 StU baskets, with moulded push bar, height of loading surface from the floor (loading height:) 300 mm                                   | 4 swivel castors Ø 125 mm, 2 of them lockable, with double ball bearings, conductive, non-slag construction and wall deflectors | 675 x 830 x 900 mm     | 542 252  |
| 5 <b>Paper stand</b>   | For sterile equipment packing paper, holds paper sheets up to 1200 mm, 4 paper bars, open on the side, with welded grating, stainless-steel square-type tube                                 | synthetic antistatic double castors, 4 swivel castors, Ø 75 mm, 2 of them lockable, with wall deflectors                        | 1345 x 545 x 900 mm    | 542 413  |
| 6 <b>Gascylinder transportation trolley</b>                    | Small, mobile gas cylinder transport trolley made of stainless-steel material. Adjustable (dia., height) holders for different cylinder sizes. Easy handling. (Gascylinder is not included.) | Available with MRI compatible castors.  | 396 x 614 x 1122 mm    | 542 176  |

# Instrument Trolleys



| <b>Instrument trolley</b>   |                 |   |        |                        |          |                     |         |
|---|-----------------|---|--------|------------------------|----------|---------------------|---------|
| <p>Mobile, jointless square tube frame construction, 20 x 20 mm, made of stainless-steel. Tube frame designed as a protective railing, top and bottom with removable stainless-steel tabletops.</p> <p>Load capacity: 50 kg</p> <p>Abrasion-resistant, non-discolouring, corrosion-resistant synthetic antistatic double castors (4 steering castors, Ø 75 mm, 2 of which have brakes with wall guard)</p>  |                 |   |        |                        |          |                     |         |
| Width   | Model by height | Tray useful dimensions  | Weight | Dimensions (W x D x H) | Item no. |                     |         |
| 1   | 675 mm          | 650 mm (H)  | 9 kg   | 675 x 475 x 650 mm     | 542 281  |                     |         |
|   | 2               | 800 mm (H)  |        |                        | 10 kg    | 675 x 475 x 800 mm  | 542 265 |
|   |                 | 900 mm (H)  |        |                        | 10 kg    | 675 x 475 x 900 mm  | 543 579 |
|   |                 | 1000 mm (H)   |        |                        | 11 kg    | 675 x 475 x 1000 mm | 543 580 |
| 770 mm  | 650 mm (H)      | Tray internal dimensions (useful):<br>680 x 585 x 15 mm (W x H x D) | 12 kg  | 770 x 675 x 650 mm     | 542 282  |                     |         |
|   | 800 mm (H)      |   | 14 kg  | 770 x 675 x 800 mm     | 542 266  |                     |         |
|   | 900 mm (H)      |   | 14 kg  | 770 x 675 x 900 mm     | 543 581  |                     |         |
|   | 1000 mm (H)     |   | 14 kg  | 770 x 675 x 1000 mm    | 543 582  |                     |         |
| 990 mm  | 800 mm (H)      | Tray internal dimensions (useful):<br>900 x 585 x 15 mm (W x H x D) | 16 kg  | 990 x 675 x 800 mm     | 542 267  |                     |         |
|   | 900 mm (H)      |   | 17 kg  | 990 x 675 x 900 mm     | 543 583  |                     |         |
|   | 1000 mm (H)     |   | 17 kg  | 990 x 675 x 1000 mm    | 543 584  |                     |         |
| <b>Instrument trolley with drawer</b>   |                 |   |        |                        |          |                     |         |
| <p>Tube frame as protective railing, 2 removable plates,<br/>           Drawer front size dimensions: 445 x 95 mm<br/>           outer dimension of drawer: 445 x 450 x 102 mm (W x H x D), useful dim.: 403 x 374 x 58 mm<br/>           Or where the size of the trolley allows, there is a longer drawer:<br/>           outer dimension of drawer: 445 x 650 x 102 mm (W x H x D), useful dim.: 403 x 574 x 58 mm<br/>           Load capacity: 50 kg<br/>           4 steering castors, Ø 75 mm with wall guard, 2 with brakes</p> |                 |   |        |                        |          |                     |         |
| Width   | Model by height | Tray useful dimensions  | Weight | Dimensions (W x D x H) | Item no. |                     |         |
| 3   | 675 mm          | Tray internal dimensions (useful):<br>585 x 385 x 15 mm (W x D x H) | 13 kg  | 675 x 475 x 650 mm     | 542 283  |                     |         |
|   |                 |   | 15 kg  | 675 x 475 x 800 mm     | 542 268  |                     |         |
| 4   | 770 mm          | Tray internal dimensions (useful):<br>680 x 585 x 15 mm (W x D x H) | 20 kg  | 770 x 675 x 800 mm     | 542 269  |                     |         |

Trolleys with galvanised castors are available upon request.

## Instrument Trolleys



| <b>Instrument trolley with 3-sided stainless-steel railing</b>  |        |                 |   |        |                        |          |
|---|--------|-----------------|---|--------|------------------------|----------|
| Tube frame as protective railing, 2 removable plates, max. load 50 kg, 4 steering castors, 75 mm dia., with wall guard, 2 with brakes   |        |                 |   |        |                        |          |
|   | Width  | Model by Height | Tray useful dimensions  | Weight | Dimensions (W x D x H) | Item no. |
| 1   | 675 mm | 650 mm (H)      | Tray internal dimensions (useful):<br>578 x 381 x 15 mm (W x D x H) | 11 kg  | 675 x 475 x 650 mm     | 542 287  |
| 2   |        | 800 mm (H)      |   | 13 kg  | 675 x 475 x 800 mm     | 542 271  |
|   |        | 1000 mm (H)     |   | 13 kg  | 675 x 475 x 1000 mm    | 543 592  |
|   | 770 mm | 650 mm (H)      | Tray internal dimensions (useful):<br>673 x 581 x 15 mm (W x D x H) | 16 kg  | 770 x 675 x 650 mm     | 542 288  |
|   |        | 800 mm (H)      |   | 14 kg  | 770 x 675 x 800 mm     | 542 272  |
|   |        | 1000 mm (H)     |   | 14 kg  | 770 x 675 x 1000 mm    | 543 594  |
|   | 990 mm | 1000 mm (H)     | Tray internal dimensions (useful):<br>893 x 581 x 15 mm (W x D x H) | 21 kg  | 990 x 675 x 1000 mm    | 543 596  |
| <b>Instrument trolley with drawer and 3-sided stainless-steel railing</b>   |        |                 |   |        |                        |          |
| Tube frame as protective railing, 2 removable plates,<br>Drawer front size dimensions (if applicable): 445 x 95 mm outer dimension of drawer: 445 x 450 x 102 mm (W x H x D),<br>useful dim.: 403 x 374 x 58 mm Or where the size of the trolley allows, there is a longer drawer:<br>outer dimension of drawer: 445 x 650 x 102 mm (W x H x D), useful dim.: 403 x 574 x 58 mm,<br>max. load 50 kg, 4 steering castors, 75 mm dia., with wall guard, 2 with brakes |        |                 |   |        |                        |          |
|   | Width  | Model by height | Tray useful dimensions  | Weight | Dimensions (W x D x H) | Item no. |
| 3   | 675 mm | 650 mm (H)      | Tray internal dimensions (useful):<br>578 x 381 x 15 mm (W x D x H) | 17 kg  | 675 x 475 x 650 mm     | 542 285  |
| 4   |        | 800 mm (H)      |   | 18 kg  | 675 x 475 x 800 mm     | 542 274  |
|   |        | 900 mm (H)      |   | 18 kg  | 675 x 475 x 900 mm     | 543 597  |

Trolleys with galvanised castors are available upon request.

# Instrument Trolleys



| <b>Instrument trolley with flush frame plate</b>  |                |                        |  |               |                               |                 |
|---|----------------|------------------------|--|---------------|-------------------------------|-----------------|
| At top: removable plate with smooth surface, bottom: tube frame as protective railing, plate removable, max. load 50 kg, 4 steering castors, 75 mm dia., with wall guard, 2 with brakes |                |                        |  |               |                               |                 |
|   | <b>Width</b>   | <b>Model by height</b> | <b>Tray dimensions</b>                   | <b>Weight</b> | <b>Dimensions (W x D x H)</b> | <b>Item no.</b> |
| <b>5</b>  | <b>689 mm</b>  | <b>800 mm (H)</b>      | Tray dimensions:<br>639 x 439 mm (W x D) | 10 kg         | 689 x 489 x 800 mm            | <b>542 278</b>  |
|   |                | <b>900 mm (H)</b>      |  | 10 kg         | 689 x 489 x 900 mm            | <b>543 603</b>  |
|   |                | <b>1000 mm (H)</b>     |  | 11 kg         | 689 x 489 x 1000 mm           | <b>543 604</b>  |
|   | <b>784 mm</b>  | <b>800 mm (H)</b>      | Tray dimensions:<br>734 x 639 mm (W x D) | 15 kg         | 784 x 689 x 800 mm            | <b>542 279</b>  |
|   |                | <b>900 mm (H)</b>      |  | 15 kg         | 784 x 689 x 900 mm            | <b>543 605</b>  |
|   | <b>1004 mm</b> | <b>800 mm (H)</b>      | Tray dimensions:<br>954 x 639 mm (W x D) | 18 kg         | 1004 x 689 x 800 mm           | <b>542 280</b>  |
|   |                | <b>900 mm (H)</b>      |  | 18 kg         | 1004 x 689 x 900 mm           | <b>543 607</b>  |
|   |                | <b>1000 mm (H)</b>     |  | 18 kg         | 1004 x 689 x 1000 mm          | <b>543 608</b>  |

## Multi-purpose Trolleys



Multi-purpose trolleys must meet the highest standards of hygiene, efficiency, durability and ease of care. All MED-Systeme units are made from stainless steel, a material that is highly resistant to even aggressive disinfectants, making thorough cleaning simple and reliable.

Jointless welding helps prevent the accumulation of dirt and germs, supporting optimal hygiene in daily use. All units are fitted with electrically conductive special castors, making them suitable for use in a wide range of professional environments.

Their design is equally convincing. Thanks to the neutral appearance of stainless steel, these multi-purpose trolleys blend seamlessly with any furniture

or interior setting. They are suitable for universal use and are particularly ideal for transporting consumables and other goods weighing up to 20 kg.

Each trolley is equipped with a practical push handle and a tubular frame that also serves as a protective railing. Removable stainless-steel tabletops are fitted at both the top and bottom levels. Rugged wall guards provide additional protection during everyday use.

All trolleys are supplied with four swivel castors with tapered ball bearings, diameter 125 mm. Two castors are fitted with brakes. The castors are electrically conductive and include thread guards.



## Multi-purpose Trolleys



1



2



3

### Multi-purpose trolley

The trolleys are suitable for universal use and particularly for transporting consumer goods up to 20 kg. With practical push handle.

Tube frame as a protective railing, top and bottom with removable stainless-steel tabletops. All trolleys are equipped with rugged wall guards. Four steering castors with tapered ball bearing, dia. 125 mm, 2 of which have brakes, electrically conductive, with thread guard.

| Model           | Design  | Dimensions (W x D x H) | Item no. |
|-----------------|---|------------------------|----------|
| 1 With 2 levels | Tube frame as protective railing,<br>2 removable plates, max. load 20 kg<br>4 steering castors, 125 mm dia., with thread guard, wall guard,<br>2 electrically conductive, with brakes | 833 x 705 x 800 mm     | 542 291  |
| 2 With 2 levels | Tube frame as protective railing,<br>2 removable plates, max. load 20 kg<br>4 steering castors, 125 mm dia., with thread guard, wall guard,<br>2 electrically conductive, with brakes | 1053 x 705 x 800 mm    | 542 292  |
| 3 With 3 levels | Tube frame as protective railing,<br>3 removable plates, max. load 20 kg<br>4 steering castors, 125 mm dia., with thread guard, wall guard,<br>2 electrically conductive, with brakes | 1053 x 705 x 1020 mm   | 542 293  |

Trolleys with galvanised castors are available upon request.

For any special request (handles, number of the trays, fixed tray, custom size, etc.), please contact your local authorized partner.

# CLEANassist

## Packing

### Precision and Efficiency for Instrument Inspection



In the packing department, careful inspection of the condition and functionality of instruments is essential, as it forms a fundamental prerequisite for successful surgical procedures. Workstations must be designed to support efficient visual and functional inspection of increasingly complex medical products. MED-Systeme packing tables are developed to meet these requirements in every detail.

**Ergonomic:** Height-adjustable tables allow the correct working height to be set at the touch of a button, whether working seated or standing. The adjustment system fully complies with workplace safety requirements.

**Variable:** Tabletops are available in a range of materials to suit different applications and preferences.

**Flexible:** The rack attachment system can be equipped with a variety of StU components, enabling customised workstation configurations.

**Modern:** Practical solutions are available for integrating monitors, keyboards, and PCs, creating a well-organised and efficient working environment.

**Bright:** Integrated lighting ensures optimum illumination of the work surface for precise inspection tasks.

**Safe:** The packing tables comply with the relevant machinery directive requirements.

**User friendly:** Additional storage space can be created, for example, by fitting base cabinets beneath the worktop.



# Packing Station



1

| <p><b>Packing station with electric height adjustment (stroke: 500 mm (720 mm - 1220 mm)) incl. tabletop of stainless-steel</b><br/>         With Media column<br/>         Rack attachment, packing station lighting, and stainless-steel tabletop<br/>         With smooth tabletop, tabletop surface 240 grain polished, 40 mm bevel on all sides<br/>         Optional: rear wall for stabilization, protection and division</p> |                        |                  | CE |
|--|------------------------|------------------|----|
| Model  | Dimensions (W x D x H) | Item no.         |    |
| 1 With 2 feet with levelable synthetic foot cleats   | 1800 x 800 x 890 mm    | <b>542 46301</b> |    |
|  | 2100 x 800 x 890 mm    | <b>542 46302</b> |    |
| <b>NOTE: Surcharge for Corian or Resopal tabletop</b>  |                        |                  |    |

Please contact your local partner for custom sizes.

# Packing Tables



## Packing table model PT

| Design   | Height |
|--|--------|
| <p>Base frame made of 40 x 40 mm square type tube</p> <p>Without tabletop, from 600–2100 mm with 4 legs, &gt; 2100 mm with 6 legs, see overview on page 39</p> <p>With synthetic feet that can be levelled and additional cross member</p> | 850 mm |

| Width          | Depth 600 mm<br>Item no. | Depth 700 mm<br>Item no. | Depth 800 mm<br>Item no. |
|----------------|--------------------------|--------------------------|--------------------------|
| <b>Legs: 4</b> |                          |                          |                          |
| 600 mm         | 542 459 01               | 542 459 34               | 542 459 67               |
| 700 mm         | 542 459 02               | 542 459 35               | 542 459 68               |
| 800 mm         | 542 459 03               | 542 459 36               | 542 459 69               |
| 900 mm         | 542 459 04               | 542 459 37               | 542 459 70               |
| 1000 mm        | 542 459 05               | 542 459 38               | 542 459 71               |
| 1100 mm        | 542 459 06               | 542 459 39               | 542 459 72               |
| 1200 mm        | 542 459 07               | 542 459 40               | 542 459 73               |
| 1300 mm        | 542 459 08               | 542 459 41               | 542 459 74               |
| 1400 mm        | 542 459 09               | 542 459 42               | 542 459 75               |
| 1500 mm        | 542 459 10               | 542 459 43               | 542 459 76               |
| 1600 mm        | 542 459 11               | 542 459 44               | 542 459 77               |
| 1700 mm        | 542 459 12               | 542 459 45               | 542 459 78               |
| 1800 mm        | 542 459 13               | 542 459 46               | 542 459 79               |
| 1900 mm        | 542 459 14               | 542 459 47               | 542 459 80               |
| 2000 mm        | 542 459 15               | 542 459 48               | 542 459 81               |
| 2100 mm        | 542 459 16               | 542 459 49               | 542 459 82               |
| <b>Legs: 6</b> |                          |                          |                          |
| 2200 mm        | 542 459 17               | 542 459 50               | 542 459 83               |
| 2300 mm        | 542 459 18               | 542 459 51               | 542 459 84               |
| 2400 mm        | 542 459 19               | 542 459 52               | 542 459 85               |
| 2500 mm        | 542 459 20               | 542 459 53               | 542 459 86               |
| 2600 mm        | 542 459 21               | 542 459 54               | 542 459 87               |
| 2700 mm        | 542 459 22               | 542 459 55               | 542 459 88               |
| 2800 mm        | 542 459 23               | 542 459 56               | 542 459 89               |
| 2900 mm        | 542 459 24               | 542 459 57               | 542 459 90               |
| 3000 mm        | 542 459 25               | 542 459 58               | 542 459 91               |
| 3100 mm        | 542 459 26               | 542 459 59               | 542 459 92               |
| 3200 mm        | 542 459 27               | 542 459 60               | 542 459 93               |
| 3300 mm        | 542 459 28               | 542 459 61               | 542 459 94               |
| 3400 mm        | 542 459 29               | 542 459 62               | 542 459 95               |
| 3500 mm        | 542 459 30               | 542 459 63               | 542 459 96               |
| 3600 mm        | 542 459 31               | 542 459 64               | 542 459 97               |
| 3700 mm        | 542 459 32               | 542 459 65               | 542 459 98               |
| 3800 mm        | 542 459 33               | 542 459 66               | 542 459 99               |

Modular tables  
with straight legs  
are also available.

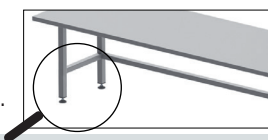

# Packing Tables



| Packing table PTB   |        |
|---|--------|
| Design  | Height |
| Base frame made of 40 x 40 mm square type tube<br>Without tabletop, from 600–2100 mm with 4 legs, > 2100 mm with 6 legs, see overview on page 39<br>With synthetic feet that can be levelled and welded shelf (single wall) | 850 mm |

| Width          | Depth 600 mm<br>Item no. | Depth 700 mm<br>Item no. | Depth 800 mm<br>Item no. |
|----------------|--------------------------|--------------------------|--------------------------|
| <b>Legs: 4</b> |                          |                          |                          |
| 600 mm         | 542 460 01               | 542 460 34               | 542 460 67               |
| 700 mm         | 542 460 02               | 542 460 35               | 542 460 68               |
| 800 mm         | 542 460 03               | 542 460 36               | 542 460 69               |
| 900 mm         | 542 460 04               | 542 460 37               | 542 460 70               |
| 1000 mm        | 542 460 05               | 542 460 38               | 542 460 71               |
| 1100 mm        | 542 460 06               | 542 460 39               | 542 460 72               |
| 1200 mm        | 542 460 07               | 542 460 40               | 542 460 73               |
| 1300 mm        | 542 460 08               | 542 460 41               | 542 460 74               |
| 1400 mm        | 542 460 09               | 542 460 42               | 542 460 75               |
| 1500 mm        | 542 460 10               | 542 460 43               | 542 460 76               |
| 1600 mm        | 542 460 11               | 542 460 44               | 542 460 77               |
| 1700 mm        | 542 460 12               | 542 460 45               | 542 460 78               |
| 1800 mm        | 542 460 13               | 542 460 46               | 542 460 79               |
| 1900 mm        | 542 460 14               | 542 460 47               | 542 460 80               |
| 2000 mm        | 542 460 15               | 542 460 48               | 542 460 81               |
| 2100 mm        | 542 460 16               | 542 460 49               | 542 460 82               |
| <b>Legs: 6</b> |                          |                          |                          |
| 2200 mm        | 542 460 17               | 542 460 50               | 542 460 83               |
| 2300 mm        | 542 460 18               | 542 460 51               | 542 460 84               |
| 2400 mm        | 542 460 19               | 542 460 52               | 542 460 85               |
| 2500 mm        | 542 460 20               | 542 460 53               | 542 460 86               |
| 2600 mm        | 542 460 21               | 542 460 54               | 542 460 87               |
| 2700 mm        | 542 460 22               | 542 460 55               | 542 460 88               |
| 2800 mm        | 542 460 23               | 542 460 56               | 542 460 89               |
| 2900 mm        | 542 460 24               | 542 460 57               | 542 460 90               |
| 3000 mm        | 542 460 25               | 542 460 58               | 542 460 91               |
| 3100 mm        | 542 460 26               | 542 460 59               | 542 460 92               |
| 3200 mm        | 542 460 27               | 542 460 60               | 542 460 93               |
| 3300 mm        | 542 460 28               | 542 460 61               | 542 460 94               |
| 3400 mm        | 542 460 29               | 542 460 62               | 542 460 95               |
| 3500 mm        | 542 460 30               | 542 460 63               | 542 460 96               |
| 3600 mm        | 542 460 31               | 542 460 64               | 542 460 97               |
| 3700 mm        | 542 460 32               | 542 460 65               | 542 460 98               |
| 3800 mm        | 542 460 33               | 542 460 66               | 542 460 99               |

Modular tables  
with straight legs  
are also available.

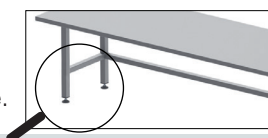

# Packing Tables



| Packing table PT-F   |                                   |
|--|-----------------------------------|
| Design   | Height                            |
| Base frame made of 40 x 40 mm square type tube, with 4 legs,<br>Without tabletop, with 4 legs, 2 cross members for stabilization, see overview on page 39<br>mobile on 4 antistatic castors Ø 125 mm, 2 lockable | 850 mm<br>(890 mm incl. tabletop) |

| Width          | Depth 600 mm<br>Item no. | Depth 700 mm<br>Item no. |
|----------------|--------------------------|--------------------------|
| <b>Legs: 4</b> |                          |                          |
| 600 mm         | 542 461 01               | 542 461 08               |
| 900 mm         | 542 461 02               | 542 461 09               |
| 1000 mm        | 542 461 03               | 542 461 10               |
| 1200 mm        | 542 461 04               | 542 461 11               |
| 1500 mm        | 542 461 05               | 542 461 12               |
| 1600 mm        | 542 461 06               | 542 461 13               |
| 2000 mm        | 542 461 07               | 542 461 14               |



| Packing table PTB-F   |                                   |
|---|-----------------------------------|
| Design  | Height                            |
| Base frame made of 40 x 40 mm square type tube, with 4 legs<br>With welded shelf (single wall) for stabilization<br>Mobile on 4 antistatic castors Ø 125 mm,<br>2 lockable castors<br>Worktop not included, please refer to page 39 | 850 mm<br>(890 mm incl. tabletop) |

| Width          | Depth 600 mm<br>Item no. | Depth 700 mm<br>Item no. |
|----------------|--------------------------|--------------------------|
| <b>Legs: 4</b> |                          |                          |
| 600 mm         | 542 462 01               | 542 462 08               |
| 900 mm         | 542 462 02               | 542 462 09               |
| 1000 mm        | 542 462 03               | 542 462 10               |
| 1200 mm        | 542 462 04               | 542 462 11               |
| 1500 mm        | 542 462 05               | 542 462 12               |
| 1600 mm        | 542 462 06               | 542 462 13               |
| 2000 mm        | 542 462 07               | 542 462 14               |

Modular tables  
with straight legs  
are also available.

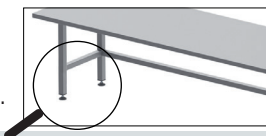

# Packing Tables - Tabletops

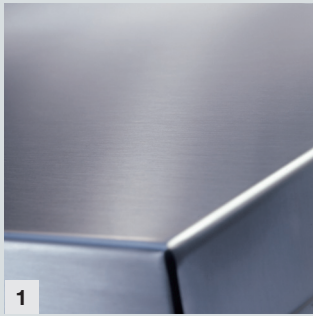

1

| Model                                     | Design  |
|---|---|
| <b>1 Tabletop made of stainless-steel</b> | Smooth tabletop, tabletop surface 240 grain polished, underside reinforced with profiles, 40 mm bevel on all sides  |
| <b>Tabletop cladding</b>                  | Additional cover for the underside of the tabletop for improved hygiene, essential for height adjustable packing tables and when installing base cabinets underneath the tabletop |



2

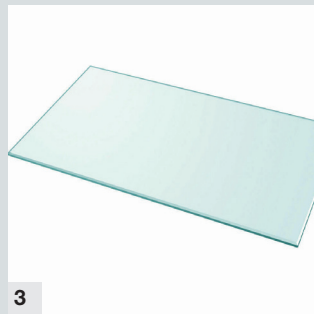

3

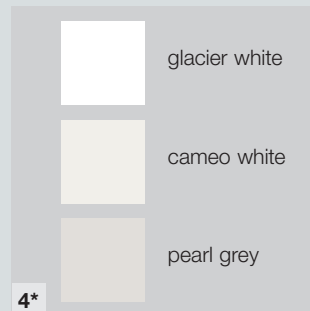

4\*



5\*

| Model   | Design  | Dimensions  |
|---|---|---|
| <b>2 Corian tabletop</b>  | Corian work surface 13 mm, doubled to 40 mm, with circumferential rounded and coated edge, radius 10 mm, thickness 40 mm, max. tabletop length: 3680 mm | For tabletop depth:<br>< 750 mm<br>750–800 mm<br>> 800 mm |
| <b>3 Acryl tabletop</b>   |   |   |
| <b>4 Colour sample for Corian tabletops - custom colours are available</b>  |   |   |
| <b>5 Colour sample for Resopal tabletops - custom colours are available</b> |   |   |

Please contact your local partner for custom sizes.

# Packing Table Equipment

## Packing Tables - Rack Attachments

| Rack attachments   |   |
|--|---|
| Design   | Installation  |
| Consists of 2 media columns made of stainless-steel<br>With welded segments made of 25 x 25 mm square tubing,<br>suitable to hold baskets, holders, and nodes;<br>for 3 storage levels spaced 320 mm apart | <b>Type 1</b><br>on tabletop,<br>hooks on one side  |
|  | <b>Type 2</b><br>between 2 packing<br>tables standing<br>back to back,<br>hooks on both sides |

| Minimum tabletop length   | Component receptacle | Component width | Hook         | Type | Dimensions (W x D x H) | Item no.          |
|---|----------------------|-----------------|--------------|------|------------------------|-------------------|
| <b>Rack attachment for tabletop of packing table, with 1 segment</b>  |                      |                 |              |      |                        |                   |
| 860 mm  | max. 3               | 600 mm          | one-sided    | 1    | 840 x 180 x 1100 mm    | <b>542 464 01</b> |
|   | max. 6               | 600 mm          | double-sided | 2    |                        | <b>542 464 02</b> |
| 1160 mm   | max. 3               | 900 mm          | one-sided    | 1    | 1140 x 180 x 1100 mm   | <b>542 464 03</b> |
|   | max. 6               | 900 mm          | double-sided | 2    |                        | <b>542 464 04</b> |
| <b>Rack attachment for tabletop of packing table, with 2 segments</b> |                      |                 |              |      |                        |                   |
| 1480 mm   | max. 6               | 600 mm          | one-sided    | 1    | 1460 x 180 x 1100 mm   | <b>542 464 05</b> |
|   | max. 12              | 600 mm          | double-sided | 2    |                        | <b>542 464 06</b> |

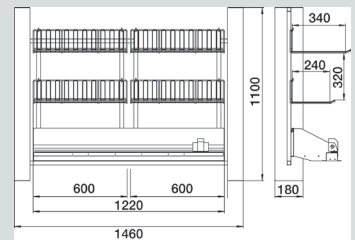
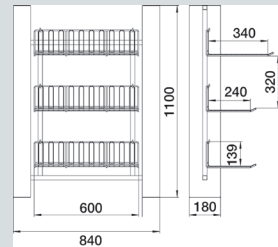

# Packing Table Equipment

## Packing Tables - Rack Attachments

| Minimum tabletop length   | Component receptacle | Component receptacle | Hook         | Type | Dimensions (W x D x H) | Item no.   |
|---|----------------------|----------------------|--------------|------|------------------------|------------|
| <b>Rack attachment for tabletop of packing table, with 2 segments</b> |                      |                      |              |      |                        |            |
| 1780 mm   | max. 6               | 600 mm               | one-sided    | 1    | 1760x180 x1100 mm      | 542 464 09 |
|   | max. 3               | 900 mm               |              |      |                        |            |
|   | max. 12              | 600 mm               | double-sided | 2    |                        | 542 464 10 |
|   | max. 6               | 900 mm               |              |      |                        |            |
| 2080 mm   | max. 6               | 900 mm               | one-sided    | 1    | 2060x180 x1100 mm      | 542 464 07 |
|   | max. 12              | 900 mm               | double-sided | 2    |                        | 542 464 08 |
| <b>Rack attachment for tabletop of packing table, with 3 segments</b> |                      |                      |              |      |                        |            |
| 2100 mm   | max. 9               | 600 mm               | one-sided    | 1    | 2080x180 x1100 mm      | 542 464 11 |
|   | max. 18              | 600 mm               | double-sided | 2    |                        | 542 464 12 |
| 2400 mm   | max. 9               | 600 mm               | one-sided    | 1    | 2380x180 x1100 mm      | 542 464 13 |
|   | max. 6               | 900 mm               |              |      |                        |            |
|   | max. 18              | 600 mm               | double-sided | 2    |                        | 542 464 14 |
|   | max. 12              | 900 mm               |              |      |                        |            |
| 2700 mm   | max. 9               | 600 mm               | one-sided    | 1    | 2680x180 x1100 mm      | 542 464 15 |
|   | max. 6               | 900 mm               |              |      |                        |            |
|   | max. 18              | 600 mm               | double-sided | 2    |                        | 542 464 16 |
|   | max. 12              | 900 mm               |              |      |                        |            |
| 3000 mm   | max. 9               | 900 mm               | one-sided    | 1    | 2980x180 x1100 mm      | 542 464 17 |
|   | max. 18              | 900 mm               | double-sided | 2    |                        | 542 464 18 |

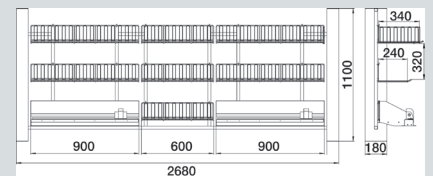
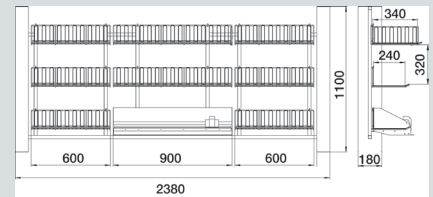
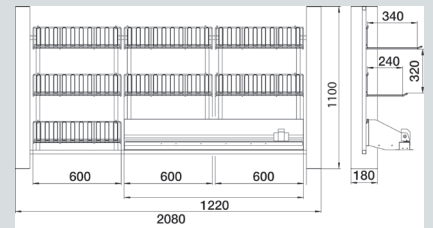
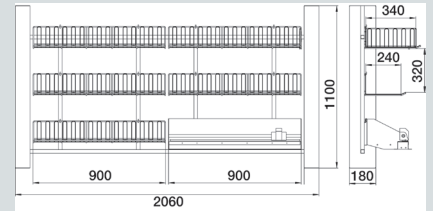
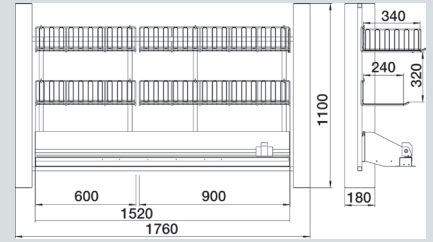

# Packing Table Equipment

## Packing Tables - Rack Accessories



1

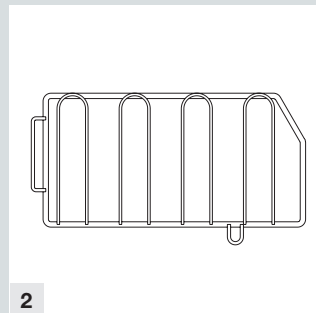

2

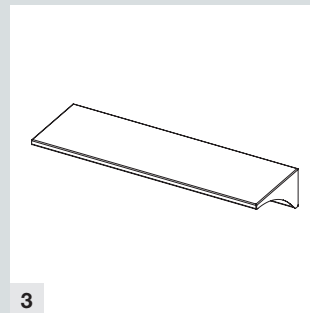

3



4

|   | Model                                 | Design   | Material  | Dimensions (W x D x H) | Item no.       |
|---|---------------------------------------|--|---|------------------------|----------------|
| 1 | <b>Storage basket with 2 brackets</b> | With access taper open to the side, matches the rack attachment, can be strung together in any number to form continuous wire sections, closed wire loops welded to the wall frame, mesh width: 25 x 25 mm<br>Wire thickness:<br>Loops: 3 mm, wall frame: 6 mm | Stainless-steel, electrolytically polished, seamless construction | 600 x 282 x 150 mm     | <b>542 440</b> |
|   |                                       |  |   | 600 x 382 x 150 mm     | <b>542 439</b> |
|   |                                       |  |   | 900 x 382 x 150 mm     | <b>542 456</b> |
| 2 | <b>Wire divider</b>                   | Equipped with wire retaining loops at the sides and bottom, can be alternatively mounted to the wall frame as a side wall limiter, removable at any time   | Stainless-steel, electrolytically polished                        | 246 x 126 mm           | <b>542 487</b> |
|   |                                       |  |   | 346 x 126 mm           | <b>542 488</b> |
| 3 | <b>Shelf</b>                          | For rack attachment, single wall   | Stainless-steel, 240 grain polished                               | 600 x 290 x 150 mm     | <b>542 524</b> |
|   |                                       |  |   | 600 x 390 x 150 mm     | <b>542 526</b> |
|   |                                       |  |   | 900 x 290 x 150 mm     | <b>542 527</b> |
|   |                                       |  |   | 900 x 390 x 150 mm     | <b>542 528</b> |
| 4 | <b>STE baskets</b>                    | Please see on page 17.   |   |                        |                |

## Packing Tables – Base Cabinets

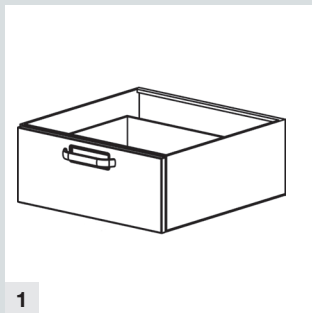

1

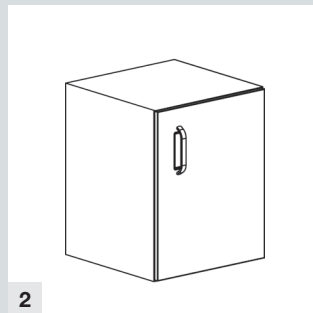

2

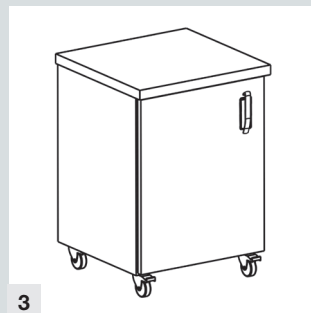

3

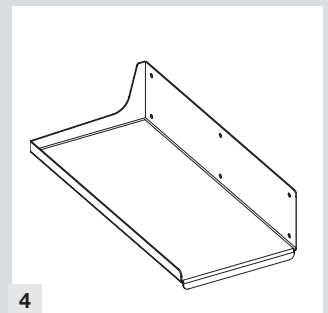

4

|   | Model  | Design   | Dimensions                     | Item no.          |
|---|--|--|--------------------------------|-------------------|
| 1 | Drawer for packing table   |  | 450 x 150 mm (W x D)           | <b>542 331 01</b> |
|   |  |  | 600 x 150 mm (W x D)           | <b>542 331 02</b> |
| 2 | Folding door base cabinet for installation under the tabletop, type MFB1 HPT | 1 folding door (hinged left or right), 1 handle  | 450 x 580 x 600 mm (W x D x H) | <b>542 495</b>    |
| 3 | Mobile base cabinet with folding door and shelf insert<br>Type MFBU          | Tabletop made of stainless-steel, edge height: 25 mm, 1 folding door, hinged left or right, 1 handle, 1 wood / synthetic shelf insert<br>4 antistatic swivel castors Ø 75 mm, 2 of them lockable | 465 x 595 x 585                | <b>537 926 04</b> |
|   |  |  | 615 x 595 x 585                | <b>537 926 08</b> |
|   | Mobile base cabinet with folding door and 2 shelf inserts<br>Type MFBU       | Tabletop made of stainless-steel, edge height: 25 mm, 1 folding door, 1 handle (handle shell, bow handle, or synthetic handle shell), 2 wood / synthetic shelf inserts                           | 465 x 595 x 735                | <b>537 926 12</b> |
|   |  |  | 615 x 595 x 735                | <b>537 926 16</b> |
| 4 | PC shelf   | Open shelf, installed underneath the tabletop, right   | 200 x 450 x 100                | <b>542 806 01</b> |
|   |  | Open shelf, installed underneath the tabletop, left  |                                | <b>542 806 02</b> |

# Packing Table Equipment

## Accessories



|   | Model  | Design                              | Material   | Dimensions (W x D x H) | Item no.       |                   |
|---|--|-------------------------------------|--|------------------------|----------------|-------------------|
| 1 | <b>Network jack</b>  | Connection provided by the customer | Stainless-steel  |                        | <b>346 426</b> |                   |
|   |  | Connection provided by the customer | Synthetic  |                        | <b>346 427</b> |                   |
|   | <b>Cable passage</b>   |                                     |  | Ø 60 mm                | <b>145 692</b> |                   |
|   | <b>Installation cut-out with socket cavity</b>               |                                     |  |                        | <b>600 781</b> |                   |
| 2 | <b>Packing table illumination for rack attachment width:</b> | <b>840 mm</b>                       | Illumination consisting of:<br>1 fluorescent lamp (21 W, length: 918 mm), tilts forward<br>1 tubular bracket<br>25 x 25 mm square tubing,<br>Rocker switch for illumination<br>Screwed to the media column | Stainless-steel        |                | <b>542 464 19</b> |
|   |  | <b>1140 mm</b>                      |  |                        |                | <b>542 464 20</b> |
|   |  | <b>1460 mm</b>                      |  |                        |                | <b>542 464 21</b> |
|   |  | <b>1760 mm</b>                      |  |                        |                | <b>542 464 22</b> |
|   |  | <b>2060 mm</b>                      |  |                        |                | <b>542 464 23</b> |
|   |  | <b>2080 mm</b>                      |  |                        |                | <b>542 464 24</b> |
|   |  | <b>2380 mm</b>                      |  |                        |                | <b>542 464 25</b> |
|   |  | <b>2680 mm</b>                      |  |                        |                | <b>542 464 26</b> |
|   |  | <b>2980 mm</b>                      |  |                        |                | <b>542 464 27</b> |

# Packing Table Equipment

## Accessories



| Model   | Design   | Dimensions (W x D x H)                         | Item no.       |
|---|--|--|----------------|
| <b>Flat screen holder incl. accessories</b>     | Can be configured with components 01–04 (when ordering, please specify the article number of the holder and the article number of the additional securing elements)  |  | <b>543 514</b> |
| <b>1 Support arm</b>                            | For mounting a standard monitor with 1-piece swivel arm and quick release, continuous adjustment in all directions for max. monitor weight of 15 kg; delivery incl. cable holder, range: 250 mm                                  |  | <b>609 793</b> |
| <b>2 Keyboard holder for keyboard and mouse</b> | For supporting computer keyboard and mouse, can be swivelled to the side if necessary. The support panel is 640 x 172 mm large and can be loaded up to 10 kg. Can be tilted to an angle of 45°. Delivery incl. two cable holders |  | <b>609 794</b> |
| <b>3 Column with drilling screw mounting</b>    | For mounting to the tabletop, for tabletops 5-70 mm thick; length: 845 mm, delivery incl. two cable clips  |  | <b>609 795</b> |
| <b>4 Cutter with roll holder</b>                | For rolls up to approx. 220 mm Ø, rolls can be inserted from above, with smooth-running cutting wheel in fully encased housing to protect against injuries, stainless-steel  | 1220x350x210 mm<br>Cutting length max. 990 mm  | <b>542 522</b> |
|   |  | 1520x350x210 mm<br>Cutting length max. 1330 mm | <b>542 523</b> |

## Transportation and Storage

Sterile goods can be transported to the storage area using open or closed trolleys, or in enclosed containers on transport trolleys. Once delivered, they are stored in the appropriate storage systems until needed for use.

MED-Systeme transport and multipurpose trolleys are designed to meet the highest standards of hygiene, efficiency, durability, and ease of cleaning. Seamless welded construction prevents the accumulation of dirt residues and germs, while electrically conductive special castors make the units suitable for all medical environments.

**High quality:** The fully welded transport trolley, slide-in rack, and transfer trolley feature seamless construction and are designed for maximum robustness in daily clinical use.

**Manoeuvrable:** Ergonomically positioned side handles improve power transmission, making even fully loaded transport trolleys easy to move and control.

**Practical:** Depending on the required storage duration, sterile goods can be stored openly on platforms, on space-saving shelving systems, or in enclosed MEGApogress functional cabinets. (For more information, see the MED-Systeme MEGApogress brochure.)



# Transport Trolleys

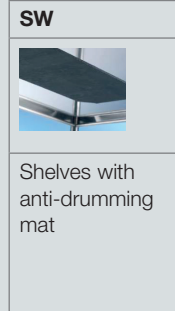

## Transport trolley

**The sturdy all-purpose trolley for every application.**

Model SW with anti-drumming mat under the shelves.

All trolleys are equipped with rugged wall guards. Castors: Four steering castors with tapered ball bearing, dia. 125 mm, 2 of which have brakes, with thread guard. Max. loading capacity: 80 kg per shelf, 120 kg total.

The tray size cannot be changed. If a variable size is required, see the instrument or all-purpose trolleys.

| Model  | Design  | Weight | Dimensions (W x D x H) | SW galvanized steel castors Item no. | SW synthetic castors Item no. |
|--|---|--------|------------------------|--------------------------------------|-------------------------------|
| <b>1</b><br><b>Transport trolley 8 x 5-2</b><br><b>Number of shelves: 2</b><br><b>800 x 500 mm</b>                     | 2 fixed shelves, 800 x 500 mm, with profile edge, 4 steering castors, 125 mm dia., with thread guard, wall guard, with brakes<br>Clearance distance between shelves: 585 mm | 17 kg  | 900 x 600 x 950 mm     | <b>555 527</b>                       | <b>569 769</b>                |
| <b>2</b><br><b>Transport trolley 8 x 5-3</b><br><b>Number of shelves: 3</b><br><b>800 x 500 mm</b>                     | 3 fixed shelves, 800 x 500 mm, with profile edge, 4 steering castors, 125 mm dia., with thread guard, wall guard, with brakes<br>Clearance distance between shelves: 275 mm | 20 kg  | 900 x 600 x 950 mm     | <b>555 528</b>                       | <b>569 770</b>                |
| <b>3</b><br><b>Transport trolley 9 x 6-2</b><br><b>Number of shelves: 2</b><br><b>900 x 550 mm</b>                     | 2 fixed shelves, 900 x 550 mm, with profile edge, 4 steering castors, 125 mm dia., with thread guard, wall guard, with brakes<br>Clearance distance between shelves: 585 mm | 18 kg  | 1000 x 650 x 950 mm    | <b>555 531</b>                       | <b>569 773</b>                |
| <b>Transport trolley 9 x 6-3</b><br><b>Number of shelves: 3</b><br><b>900 x 550 mm</b>                                 | 3 fixed shelves, 900 x 550 mm, with profile edge, 4 steering castors, 125 mm dia., with thread guard, wall guard, with brakes<br>Clearance distance between shelves: 275 mm | 22 kg  | 1000 x 650 x 950 mm    | <b>555 532</b>                       | <b>569 774</b>                |
| <b>Transport trolley 10 x 6-2</b><br><b>with steering castors</b><br><b>Number of shelves: 2</b><br><b>1000x600 mm</b> | 2 fixed shelves, 1000 x 600 mm, with profile edge, 4 steering castors, 125 mm dia., with thread guard, wall guard, with brakes  | 25 kg  | 1100 x 700 x 1010 mm   | <b>573 487</b>                       | <b>573 486</b>                |
| <b>Transport trolley 10 x 6-3</b><br><b>with steering castors</b><br><b>Number of shelves: 3</b><br><b>1000x600 mm</b> | 3 fixed shelves, 1000 x 600 mm, with profile edge, 4 steering castors, 125 mm dia., with thread guard, wall guard, with brakes  | 31 kg  | 1100 x 700 x 1000 mm   | <b>573 489</b>                       | <b>573 488</b>                |

### Castor design

| SW  | SW  |
|---|---|
|  |  |
| Swivel castor with galvanized steel brake   | Swivel castor with synthetic break  |

## General Transport Trolleys



|   | Model / Design   | Dimensions (W x D x H) | Item no.       |
|---|--|------------------------|----------------|
|   | <b>Open transport trolley with shelves*</b>  |                        |                |
|   | Open 25 x 25 mm square tubular frame construction, made of stainless-steel<br>With 3 removable shelves (max. loading capacity 60 kg per shelf)<br>4 conductive swivel castors Ø 125 mm, 2 of them lockable, with wall deflectors   |                        |                |
| 1 | Holds max. 6 StU sterile equipment<br>(for a maximum of 3 small shelves à 679 x 564 x 30 mm)   | 760 x 695 x 1397 mm    | <b>543 137</b> |
| 2 | Holds max. 9 StU Sterilgut<br>(for a maximum of 3 large shelves à 1009 x 564 x 30 mm)  | 1090 x 695 x 1397 mm   | <b>543 139</b> |
|   | <b>Open transport trolley with support brackets*</b>   |                        |                |
|   | Open 25 x 25 mm square-type tube frame construction, single-walled, made of stainless-steel<br>With 6 pairs of height adjustable support brackets, (max. loading capacity 20 kg per pair of angled support brackets)<br>4 conductive swivel castors Ø 125 mm, 2 of them lockable, with wall deflectors |                        |                |
| 3 | Holds max. 6 StU sterile equipment, with 6 pairs of support brackets<br>(incl. 1 StU frame for support brackets)   | 760 x 695 x 1397 mm    | <b>543 138</b> |
| 4 | Holds max. 9 StU sterile equipment, with 9 pairs of support brackets<br>(incl. 2 StU frames for support brackets)  | 1090 x 695 x 1397 mm   | <b>543 140</b> |

\* Can be interchanged in seconds – to shelves or support brackets depending on the model – completely without tools.

# Sterile Transport Trolleys

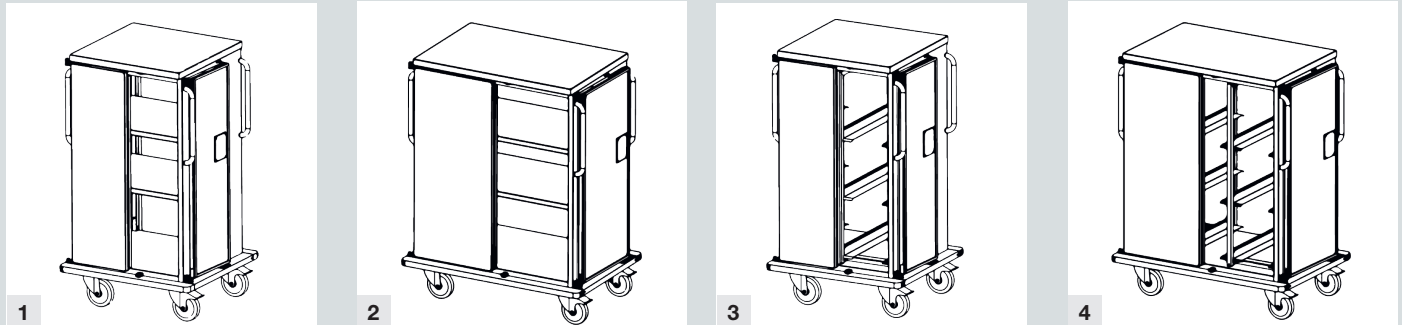

| Model / Design   | External dimensions (WxDxH)<br>Internal dimensions (WxDxH) | Empty weight | Item no.       |
|--|--|--------------|----------------|
| <b>Enclosed container transport trolley with shelves*</b>  |  |              |                |
| Closed single-walled construction in stainless-steel,<br>2 double-walled folding doors with circumferential seal and stop rail, door with opening angle 270°, lockable at 255°,<br>2 removable shelves, 4 push handles mounted vertically on the sides, all-round massive bumper strip,<br>4 conductive swivel castors, 2 of them lockable, loading capacity: 200 kg, max. capacity per shelf: 60 kg   |  |              |                |
| <b>1</b> Holds max. 6 StU sterile equipment  | 840 x 785 x 1485 mm<br>634 x 622 x 1132 mm                 | 94,5 kg      | <b>543 131</b> |
| <b>2</b> Holds max. 9 StU sterile equipment  | 1170 x 785 x 1485 mm<br>964 x 622 x 1132 mm                | 117,5 kg     | <b>543 133</b> |
| <b>Closed container transport trolley with support brackets</b>  |  |              |                |
| Closed single-walled construction in stainless-steel with 12 pairs of height adjustable support brackets,<br>2 double-walled folding doors with circumferential seal and stop rail, door with opening angle 270°, lockable at 255°,<br>4 push handles mounted vertically on the sides, all-round massive bumper strip,<br>4 conductive swivel castors, 2 of them lockable,<br>loading capacity: 200 kg |  |              |                |
| <b>3</b> Holds max. 6 StU sterile equipment, 6 pairs of support brackets<br>(incl. 1 STW frame for support bracket, 2 connecting profiles for STW Frame and 1 fixing profile for STW frame)  | 840 x 785 x 1485 mm<br>634 x 622 x 1132 mm                 | 102,5 kg     | <b>543 132</b> |
| <b>4</b> Holds max. 9 StU sterile equipment, 9 pairs of support brackets<br>(incl. 2 STW frame for support bracket, 4 connecting profiles for STW Frame and 2 fixing profile for STW frame)  | 1170 x 785 x 1485 mm<br>964 x 622 x 1132 mm                | 130,5 kg     | <b>543 134</b> |

\* Can be interchanged in seconds – to shelves or support brackets depending on the model – completely without tools.

## Sterile Transport Trolleys

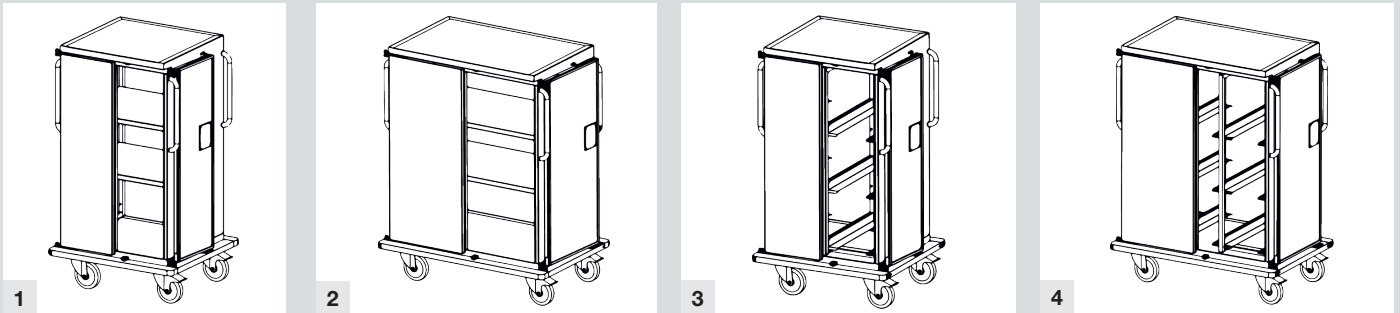

| Model / Design   | Exterior dimensions (W x D x H)<br>Interior dimensions (W x D x H) | Empty weight | Item no.       |
|--|--|--------------|----------------|
| <b>Closed transport trolley, fully-welded, with shelves*</b>   |  |              |                |
| Closed fully-welded model in stainless-steel, suitable for washing systems in connection with stainless-steel rollers (not included, see accessories below: MC 0357), 2 double-walled folding doors with circumferential seal and stop rail, door with opening angle 270°, lockable at 255°, with 2 removeable, height-adjustable shelves, two vertical stainless-steel push handles on each of the two sides, all-round massive bumper strip, 2-point locking 4 galvanised swivel castors Ø 160 mm, 2 of them lockable, for indoor/outdoor transport, loading weight 180 kg, max. loading capacity per shelf: 60 kg |  |              |                |
| 1 Holds max. 6 StU sterile equipment   | 850 x 780 x 1495 mm<br>664 x 622 x 1132 mm                         | 107 kg       | <b>543 194</b> |
| 2 Holds max. 9 StU sterile equipment   | 1180 x 785 x 1485 mm<br>994 x 622 x 1132 mm                        | 113 kg       | <b>543 196</b> |
| <b>Closed container transport trolley, fully-welded, with support brackets</b>   |  |              |                |
| Closed fully-welded model in stainless-steel, suitable for washing systems in connection with stainless-steel rollers, 2 double-walled folding doors with circumferential seal and stop rail, door with opening angle 270°, lockable at 255°, 2-point locking, 4 galvanised swivel castors Ø 160 mm, 2 of them lockable, for indoor/outdoor transport, loading weight 180 kg, max. loading capacity per support bracket: 20 kg   |  |              |                |
| 3 Holds max. 6 StU sterile equipment with 6 pairs of height-adjustable support brackets (incl. 1 STW frame for support bracket, 2 connecting profiles for STW frame)   | 850 x 780 x 1495 mm<br>664 x 622 x 1132 mm                         | 132 kg       | <b>543 195</b> |
| 4 Holds max. 9 StU sterile equipment with 9 pairs of height-adjustable support brackets (incl. 2 STW frame for support bracket, 4 connecting profiles for STW frame)   | 1180 x 785 x 1485 mm<br>994 x 622 x 1132 mm                        | 144 kg       | <b>543 197</b> |
| <b>Accessories for container transport trolley</b>   |  |              |                |
| Small shelf, single-walled, for entire trolley width, stainless-steel  | Dimensions (W x D x H): 679 x 564 x 30 mm                          |              | <b>353 471</b> |
| Large shelf, single-walled, for entire trolley width, stainless-steel  | Dimensions (W x D x H): 1009 x 564 x 30 mm                         |              | <b>353 472</b> |
| Perforated shelf, stainless-steel  | Dimensions (W x D x H): 308 x 559 x 30 mm                          |              | <b>600 777</b> |
| STW frame for support angels   | Dimensions (W x D x H): 25 x 618 x 1147 mm                         |              | <b>353 479</b> |
| Connecting profile for frame (2 pieces)  |  |              | <b>353 513</b> |
| Fixing profile for frame   |  |              | <b>353 503</b> |
| 1 pair of support ledges   | Dimensions (W x D x H): 60 x 600 x 50 mm                           |              | <b>542 889</b> |
| Heavy-load extension - for hooking into pins for STE inner frame and shelf   | Dimensions (W x D x H): 292 x 600 mm                               |              | <b>542 529</b> |
| 4 steering castors, stainless-steel, suitable for washing systems, non-antistatic Ø 160 mm   |  | Ø 160 mm     | <b>MC0357</b>  |
| All-round bumper rail  |  |              | <b>MC0353</b>  |
| 4 corner guards with 4 middle buffers  |  |              | <b>MC0351</b>  |
| Door lock, 255°  |  |              | <b>MC0355</b>  |
| Card holder  | Dimensions (W x D x H): 215 x 5 x 130 mm                           |              | <b>353 846</b> |
| Lead-sealing device  |  |              | <b>542 966</b> |
| Lock   |  |              | <b>MC0356</b>  |
| Ground cable   |  |              | <b>MC0350</b>  |

\* Can be interchanged in seconds – to shelves or support brackets depending on the model – completely without tools.

# Storage Systems

## Flexible Solutions for Every Requirement



Space-saving storage systems are in particularly high demand in medical environments. From closed storage in StU cabinets and pass-through cabinets to container slide-in pass-through cabinets and open storage on StU shelves and shelving units, MED-Systeme offers flexible, modular storage solutions tailored to individual requirements.

### **Cabinet systems:**

MED-Systeme cabinet systems combine robust construction, hygienic design, and flexible interior organisation to ensure safe and efficient storage of sterile goods.

- Available in stainless-steel or powder-coated sheet steel
- Double-walled sandwich construction for maximum stability
- Patented hinge mechanism with locking function for secure and hygienic storage of sterile equipment
- Flexible interior fittings, including shelves, support brackets, and heavy-duty pull-outs

### **Shelving systems:**

MED-Systeme shelving systems provide hygienic and space-efficient open storage solutions with a high degree of adaptability.

- Manufactured entirely from stainless-steel
- Available as StU shelving with support brackets or pull-outs
- Shelving units with single-walled or double-walled shelf design
- Flexible dimensions for precise adaptation to the available space
- Height-adjustable storage components
- Hygienic construction for easy cleaning and long-term reliability

## StU Storage Cabinets - Cabinet Systems

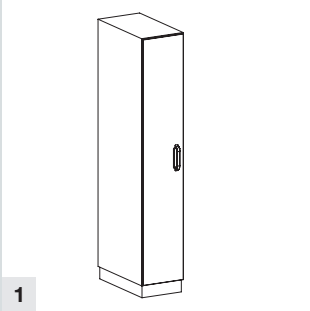

1

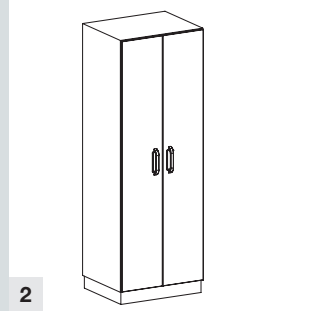

2

|   | Design                       | Capacity            | Dimensions (WxDxH)   | Material                   | Item no.          |
|---|------------------------------|---------------------|----------------------|----------------------------|-------------------|
| <b>StU vertical cabinet</b>   |                              |                     |                      |                            |                   |
| Type CMFBH, with folding door, door hinged on the right or left with one folding door, holds StU containers or sterile equipment baskets, with stainless-steel interior shelf to hold StU storage components, double-walled sandwich construction, cabinet without interior equipment |                              |                     |                      |                            |                   |
| 1   | 1 folding door<br>1 handle   | for max. 11 1/2 STU | 400 x 680 x 2100 mm  | Sheet steel, powder-coated | <b>542 931 01</b> |
|   |                              |                     |                      | Stainless-steel            | <b>542 933 01</b> |
| 2   | 2 folding doors<br>2 handles | for max. 22 1/2 STU | 730 x 680 x 2100 mm  | Sheet steel, powder-coated | <b>542 932 01</b> |
|   |                              |                     |                      | Stainless-steel            | <b>542 934 01</b> |
|   | 2 folding doors<br>2 handles | for max. 33 1/2 STU | 1060 x 680 x 2100 mm | Sheet steel, powder-coated | <b>542 932 02</b> |
|   |                              |                     |                      | Stainless-steel            | <b>542 934 02</b> |

## Slide-In / Pass-Through Cabinets

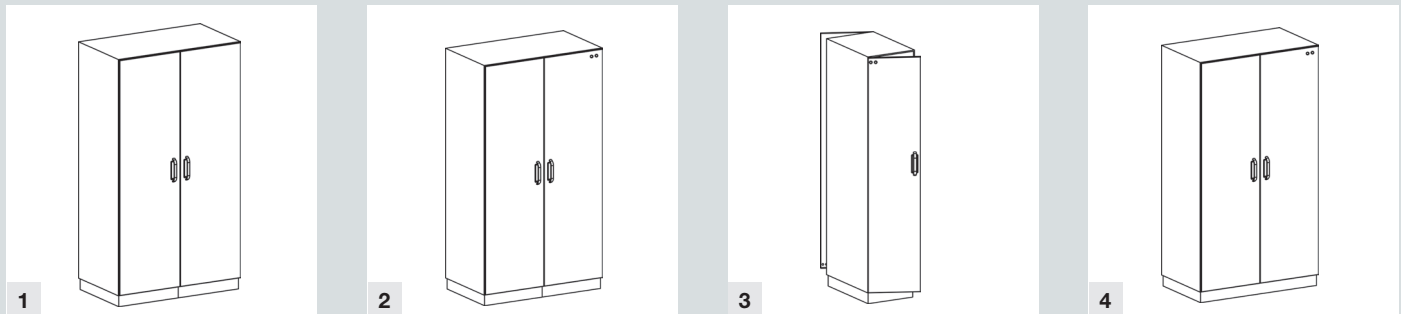

| Design   | Dimensions           | Material                   | Item no.          |
|--|----------------------|----------------------------|-------------------|
| <b>1 Slide-in cabinet*</b>   |                      |                            |                   |
| Suitable for container transport trolleys, type MBHEE, with doors with integrated plinth, double-walled sandwich construction, without interior equipment, with rear wall  |                      |                            |                   |
| 2 folding doors, 2 handles   | 1200 x 920 x 2100 mm | Sheet steel, powder-coated | <b>537 629 01</b> |
|  |                      | Stainless-steel            | <b>547 629 01</b> |
| <b>2 Slide-in, pass-through cabinet*</b>   |                      |                            |                   |
| Suitable for container transport trolleys, ideal as a pass-through between a sterile and non-sterile area, type MFBHDF with 4 opposite folding doors, with two-way electromagnetic interlock, with doors with integrated plinth, double-walled sandwich construction, without interior equipment |                      |                            |                   |
| 4 folding doors<br>4 handles   | 1200 x 920 x 2100 mm | Sheet steel, powder-coated | <b>542 397 01</b> |
|  |                      | Stainless-steel            | <b>542 386 01</b> |
| <b>Pass-through cabinet*</b>   |                      |                            |                   |
| Ideal as a pass-through between a sterile and non-sterile area, type MFBDRH with opposite folding doors, with two-way electromagnetic interlock, equipped with 4 shelves, double-walled sandwich construction  |                      |                            |                   |
| <b>3</b> 2 folding doors<br>Door hinged right or left, 2 handles<br>(1 folding door and 1 handle<br>up to a width of 660 mm)   | 600 x 700 x 2100 mm  | Sheet steel, powder-coated | <b>542 005 01</b> |
|  |                      | Stainless-steel            | <b>542 008 01</b> |
| <b>4</b> 4 folding doors, 4 handles<br>(2 folding doors and 2 handles<br>up to a width of 660 mm)  | 1200 x 700 x 2100 mm | Sheet steel, powder-coated | <b>542 006 01</b> |
|  |                      | Stainless-steel            | <b>542 007 01</b> |

Please contact your local partner for custom sizes.

# Pass-Through Cabinets



1



2

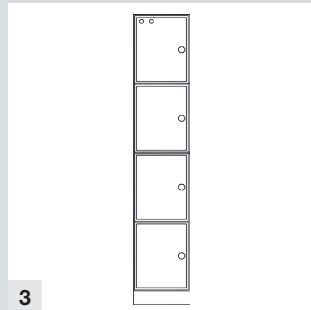

3

|  | Design   |   | Dimensions           | Material                   | Item no.          |
|--|--|---|----------------------|----------------------------|-------------------|
| <b>Lockable pass-through cabinet</b>   |  |   |                      |                            |                   |
| Ideal as a pass-through between a sterile and non-sterile area, type MFBHDR with opposite folding doors, with two-way electromagnetic interlocks, equipped with 4 shelves, double-walled sandwich construction |  |   |                      |                            |                   |
| 1  | 2 folding doors, hinged left or right  | Espagnolette lock<br>2 handles                      | 600 x 700 x 2100 mm  | Sheet steel, powder-coated | <b>542 395 01</b> |
|  |  |   |                      | Stainless-steel            | <b>542 367 01</b> |
|  |  | Espagnolette lock with thumb turn knob<br>No handle | 900 x 700 x 2100 mm  | Sheet steel, powder-coated | <b>542 395 06</b> |
|  |  |   |                      | Stainless-steel            | <b>542 367 06</b> |
| 2  | 4 folding doors  | Espagnolette lock<br>4 handles                      | 1200 x 700 x 2100 mm | Sheet steel, powder-coated | <b>542 396 01</b> |
|  |  |   |                      | Stainless-steel            | <b>542 394 01</b> |
|  |  | Espagnolette lock with thumb turn knob<br>No handle | 1200 x 700 x 2100 mm | Sheet steel, powder-coated | <b>542 396 05</b> |
|  |  |   |                      | Stainless-steel            | <b>542 396 05</b> |
| <b>Interlock for pass-through installations</b>  |  |   |                      |                            |                   |
| Two-way electromagnetic lock, with two opposite doors for pass-through shelf and pass-through cabinet  |  |   |                      |                            | <b>340 457</b>    |
| <b>Pass-through shelf for StU dimensions</b>   |  |   |                      |                            |                   |
| 3  | Suitable for installation in wall apertures or as a room divider, self-supporting stainless-steel construction, semi-gloss finish, 180 grit polished, 4 frontal folding doors, 4 handles, lockable with thumb turn knob, double-walled sandwich construction, 4 compartments |   |                      |                            |                   |
|  | Rear side open   | 400 x 680 x 2100 mm                                 | Stainless-steel      | <b>537 998 01</b>          |                   |
|  | Rear side with folding door, lockable  |   |                      | <b>537 998 02</b>          |                   |
| <b>Pass-through shelf for ISO dimensions</b>   |  |   |                      |                            |                   |
| 3  | Suitable for installation in wall apertures or as a room divider, self-supporting stainless-steel construction, semi-gloss finish, 180 grit polished, 4 frontal folding doors, hinged right, lockable with thumb turn knob, 4 handles, double-walled sandwich construction   |   |                      |                            |                   |
|  | Rear side open   | 460 x 680 x 2100 mm                                 | Stainless-steel      | <b>537 999 01</b>          |                   |
|  | Rear side with folding door, lockable  |   |                      | <b>537 999 02</b>          |                   |

## StU Shelf

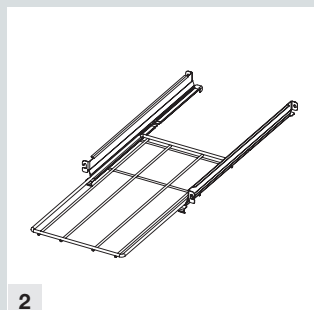

| Design  | Capacity   | Dimensions (W x D x H)                  | Item no.                                       |                |
|---|--|---|--|----------------|
| <b>StU shelf made of stainless-steel</b>  |  |   |  |                |
| <b>1 StU shelf single</b><br>element with adjustable feet and synthetic cover caps      | Consists of 2 shelf uprights, crossbar, top and bottom panels, max. 600 kg shelf load  | Max. 11 x 1/2 StU baskets per StU shelf | 355 x 615 x 2100 mm<br>Height increment 170 mm | <b>542 908</b> |
| <b>StU add-on shelf</b><br>single element with adjustable feet and synthetic cover caps | Consisting of 1 shelf upright, top and bottom panels<br>Max. 600 kg shelf load   | Max. 11 x 1/2 StU baskets per StU shelf | 330 x 615 x 2100 mm<br>Height increment 85 mm  | <b>542 917</b> |
| <b>StU shelf upright</b>  | With threaded feet and synthetic cover caps  |   | 615 x 2100 mm<br>Height increment 85 mm        | <b>542 907</b> |
| <b>Crossbar for shelf upright</b>   | For installation and stabilization of the StU shelf  |   |  | <b>543 238</b> |
| <b>1 pair of support brackets for StU shelf</b>   | Required quantity per base shelf: 1 to 11 pairs  |   | 60 x 600 x 50 mm                               | <b>542 889</b> |
| <b>Spacer for StU shelf</b>   |  |   |  | <b>542 878</b> |
| <b>Slotted shelf panel for StU shelf</b>  |  |   | <b>600 777</b>                                 |                |
| <b>Shelf panel, closed, for StU shelf</b>   |  |   | <b>600 778</b>                                 |                |
| <b>StU heavy-duty pull-out</b>  |  |   |  |                |
| <b>2</b>  | For StU cabinets, StU shelf, and shuttle system<br>Holds containers and sterile equipment baskets<br>Consists of 1 wire shelf and 2 support brackets with synthetic slide rail, with 2/3 pull-out and extension stop, for insertion<br>Max. capacity 25 kg<br>Stainless-steel, electrolytically polished |   | 292 x 600 mm<br>(Wire shelf dimensions)        | <b>542 529</b> |

# Shelving Systems

**Order information:** The MED shelving systems are available in various heights, widths, and depths.

All shelves are add-on shelves that can be expanded as required. In addition, you can expand and combine shelves of various heights or attach a narrow shelf to a wide one. Angled installation is also possible. The shelf uprights are equipped with crossbars on the rear, which are joined using screws.

A single assembled base shelf consists of:  
2 shelf uprights and 1 crossbar



A base shelf with add-on shelf consists of:  
3 shelf uprights and 1 crossbar



A shelf with 3 shelf sections consists of:  
4 shelf uprights and 1 crossbar

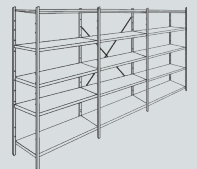

Due to the screwed crossbars, the shelf uprights are perfectly stable. Therefore mounting a crossbar behind every third shelf is sufficient. 2 crossbars are required for 4 to 6 shelves. The number of crossbars is incremented according to the number of shelf uprights.

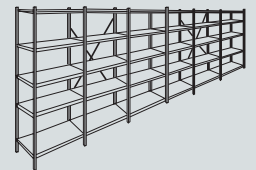

Add-on shelves are smaller than the base shelf. All that is required is an additional shelf upright. The add-on system creates size deviations from the dimensions of the base shelf. The size deviations of the MED shelves are shown in the illustration.

For evenly distributed loads, the shelf capacity is as follows:  
Metal grate shelves: 600–1000 mm wide 150 kg  
1200–1500 mm wide 100 kg  
Solid shelves: 600–1200 mm wide 150 kg  
1400–1500 mm wide 125 kg

Total gross weight: 1200 kg.  
Technical changes reserved.

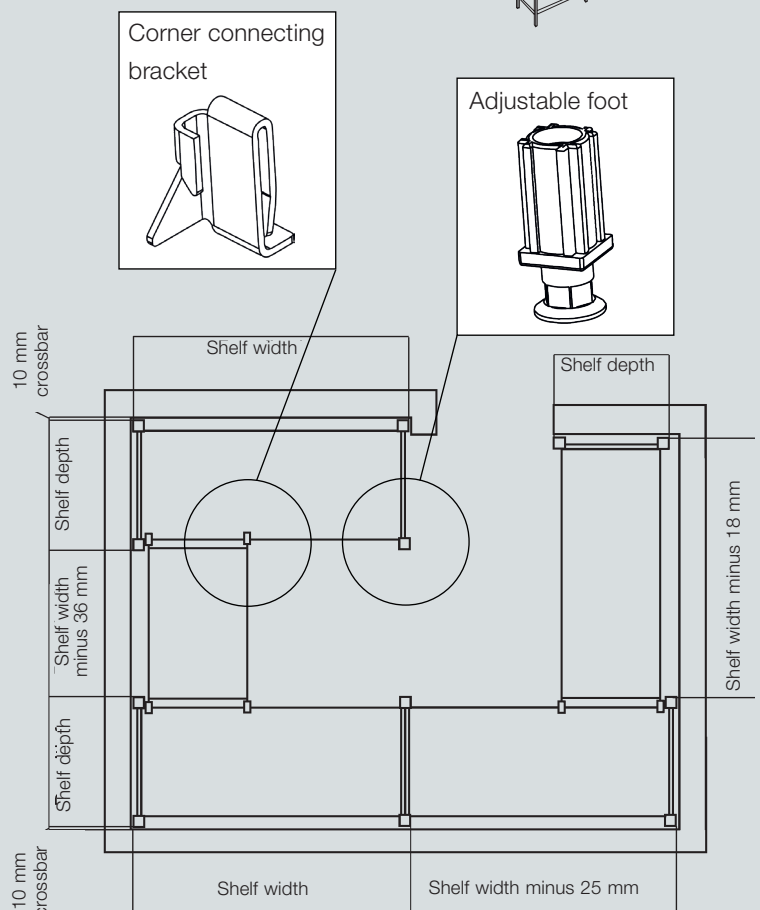

# Stainless-steel Shelving System

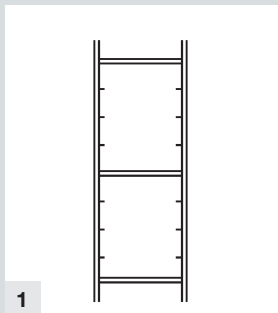

1

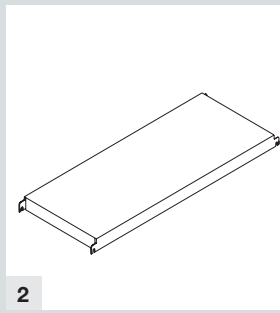

2

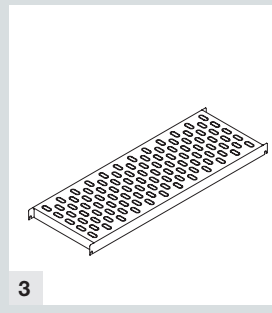

3

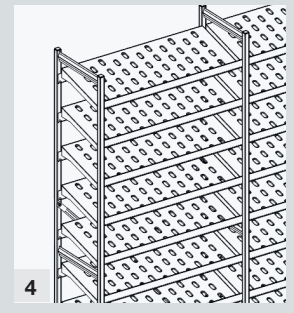

4

| 1 Shelf upright |                    |                    |                    |                    |
|-----------------|--------------------|--------------------|--------------------|--------------------|
| Height in mm    | Item no.           |                    | Item no.           |                    |
|                 | Shelf depth 300 mm | Shelf depth 400 mm | Shelf depth 500 mm | Shelf depth 600 mm |
| 1800            | 542 796            | 542 797            | 542 798            | 542 799            |
| 2000            | 542 800            | 542 801            | 542 802            | 542 803            |
| 2100            | 542 602            | 542 603            | 542 604            | 542 605            |

| 2 Enclosed support for shelf systems, smooth floor, single-walled |                    |                    |                    |                    |
|---|--------------------|--------------------|--------------------|--------------------|
| Width in mm   | Item no.           |                    | Item no.           |                    |
|   | Shelf depth 300 mm | Shelf depth 400 mm | Shelf depth 500 mm | Shelf depth 600 mm |
| 600   | 542 696            | 542 708            | 542 719            | 542 730            |
| 800   | 542 698            | 542 710            | 542 721            | 542 732            |
| 900   | 542 699            | 542 711            | 542 722            | 542 733            |
| 1000  | 542 700            | 542 712            | 542 723            | 542 734            |
| 1200  | 542 703            | 542 714            | 542 725            | 542 736            |
| 1400  | 542 705            | 542 716            | 542 727            | 542 738            |
| 1500  | 542 706            | 542 717            | 542 728            | 542 739            |

| 3 Metal grate shelf panel, slotted floor |         |         |         |         |
|--|---------|---------|---------|---------|
| 600                                      | 542 608 | 542 618 | 542 630 |         |
| 800                                      | 542 610 | 542 620 | 542 632 | 542 643 |
| 900                                      | 542 611 | 542 621 | 542 633 |         |
| 1000                                     | 542 612 | 542 622 | 542 634 |         |
| 1200                                     | 542 614 | 542 624 | 542 636 |         |
| 1400                                     | 542 615 | 542 627 | 542 638 |         |
| 1500                                     | 542 616 | 542 628 | 542 639 |         |

| Model                                   | Design                                 | Dimensions              |
|---|--|-------------------------|
| 4 Tilted version of the shelving system | Available with smooth or slotted floor | Dimensions upon request |

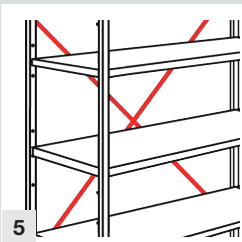

5

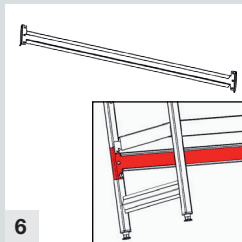

6

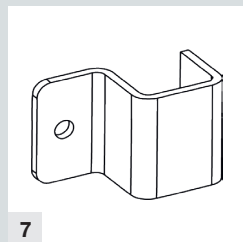

7

| Model  | Material        | Dimensions (W x H x D)  | Item no. |
|--|-----------------|-------------------------|----------|
| 5 Crossbar for shelf upright                 | Stainless-steel |                         | 542 784  |
| 6 Straight traverse                          | Stainless-steel | Dimensions upon request |          |
| 7 Wall-mount (Without installation hardware) | Stainless-steel | 40 x 55 x 29 mm         | 542 921  |

## Stainless-steel Shelf System

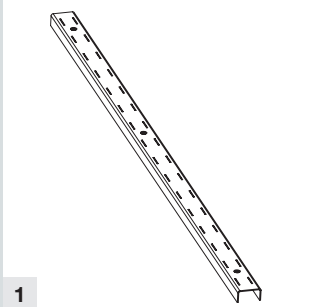

1

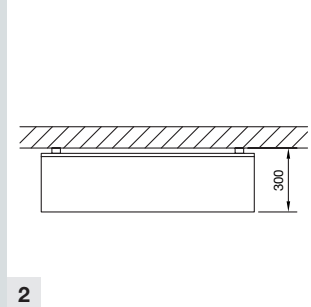

2

|   | Model  | Design  |   | Dimensions   | Item no.          |                   |
|---|--|---|---|--------------|-------------------|-------------------|
| 1 | <b>Wall rails<br/>Type VS</b>                                    | Stainless-steel   | Equipped with incremented slots to mount the consoles,<br>grid height 75 mm | 300 mm long  | <b>536 995 01</b> |                   |
|   |  |   |   | 600 mm long  | <b>536 995 02</b> |                   |
|   |  |   |   | 900 mm long  | <b>536 995 03</b> |                   |
|   |  |   |   | 1200 mm long | <b>536 995 04</b> |                   |
|   |  |   |   | 1500 mm long | <b>536 995 05</b> |                   |
|   |  |   |   | 1800 mm long | <b>536 995 06</b> |                   |
|   |  |   |   | 2000 mm long | <b>536 995 07</b> |                   |
| 2 | <b>Smooth wall shelf<br/>with polished finish,<br/>240 grain</b> | 30 mm bevel on all sides,<br>capacity with evenly<br>distributed load:<br>75 kg per linear m,<br>with rear stand-up shelf | double-walled   | max. 700 mm  | 300 mm deep       | <b>536 400 01</b> |
|   |  |   |   |              | 400 mm deep       | <b>536 400 02</b> |
|   |  |   |   | max. 500 mm  | 500 mm deep       | <b>536 400 03</b> |
|   |  |   |   |              | 600 mm deep       | <b>536 400 04</b> |



# MED-Systeme

MED-Systeme GmbH  
Johanna-Waescher-Straße 13.  
D-34131 Kassel  
+49 7269-32299-60  
sales@med-systeme.de

[www.med-systeme.com](http://www.med-systeme.com)